

- 1 POST TO WITHSTAND 13 NEWTONS (3LBS.) MIN. AXIAL FORCE IN BOTH DIRECTIONS SHOWN WITHOUT DISLODGING.
- 2 TOLERANCES APPLY TO SOLDER SIDE OF BOARD.
- 3 MEASURED AT SURFACE [-A-]
- 4 PLASTIC FLASH PERMITTED IN THIS AREA.
- 5 PARTS COMPLY WITH AMP SOLDERABILITY SPEC. NO. 109-11-2.
- 6 ONE HOLE MAY BE UNDERSIZED (.065/.060 DIA.) FOR ASSEMBLY RETENTION DURING WAVE SOLDERING.
- 7 MATERIAL: HEADER-THERMOPLASTIC POLYESTER  
GLASS-FILLED 94V-0 (NATURAL)  
POST-COPPER ALLOY (TIN PLATED)
- 8 COORDINATE DIMENSION APPLIES FROM CENTER OF ACTUAL FEATURE.
- 9 PLASTIC BURRS CAUSED BY CUT-OFF TOOLING ARE PERMITTED WITHIN THE MAXIMUM TOLERANCE ENVELOPE.
- 10 POST TO BE MEASURED WHEN STRIP IS HELD FLAT.
- 11 POST MUST WITHSTAND TWO 90° BENDS AGAINST EXTRUSION WITHOUT BREAKING.
- 12 DIMENSION SHOULD BE .175 MIN WHEN MATING WITH A MTA 156 CONNECTOR ASSEMBLY OR A SL-156 CONNECTOR ASSEMBLY.
- 13 PIN BURR OF .005 MAX. VERTICAL AND .003 MAX. HORIZONTAL PERMITTED AT POST TIPS ON BOTH ENDS.
- 14 SPECIAL PACKAGING VARIATION FOR IMPROVED PRODUCT PROTECTION.

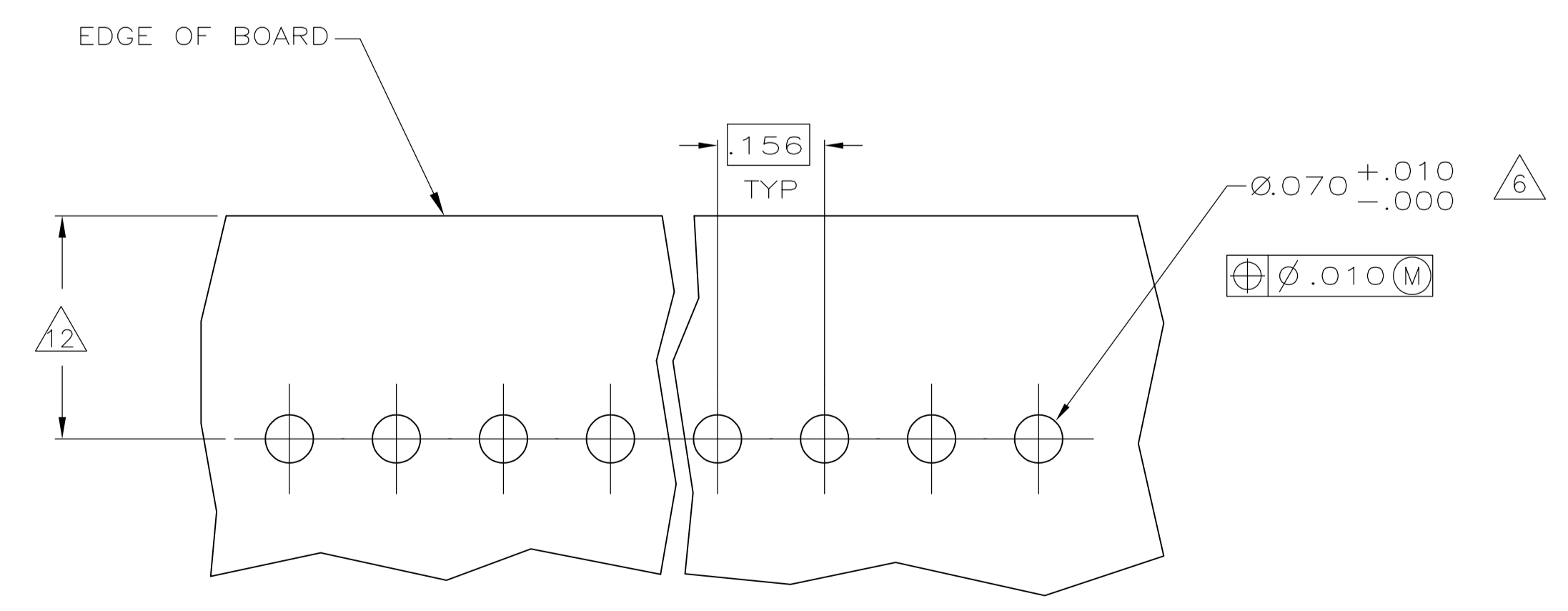
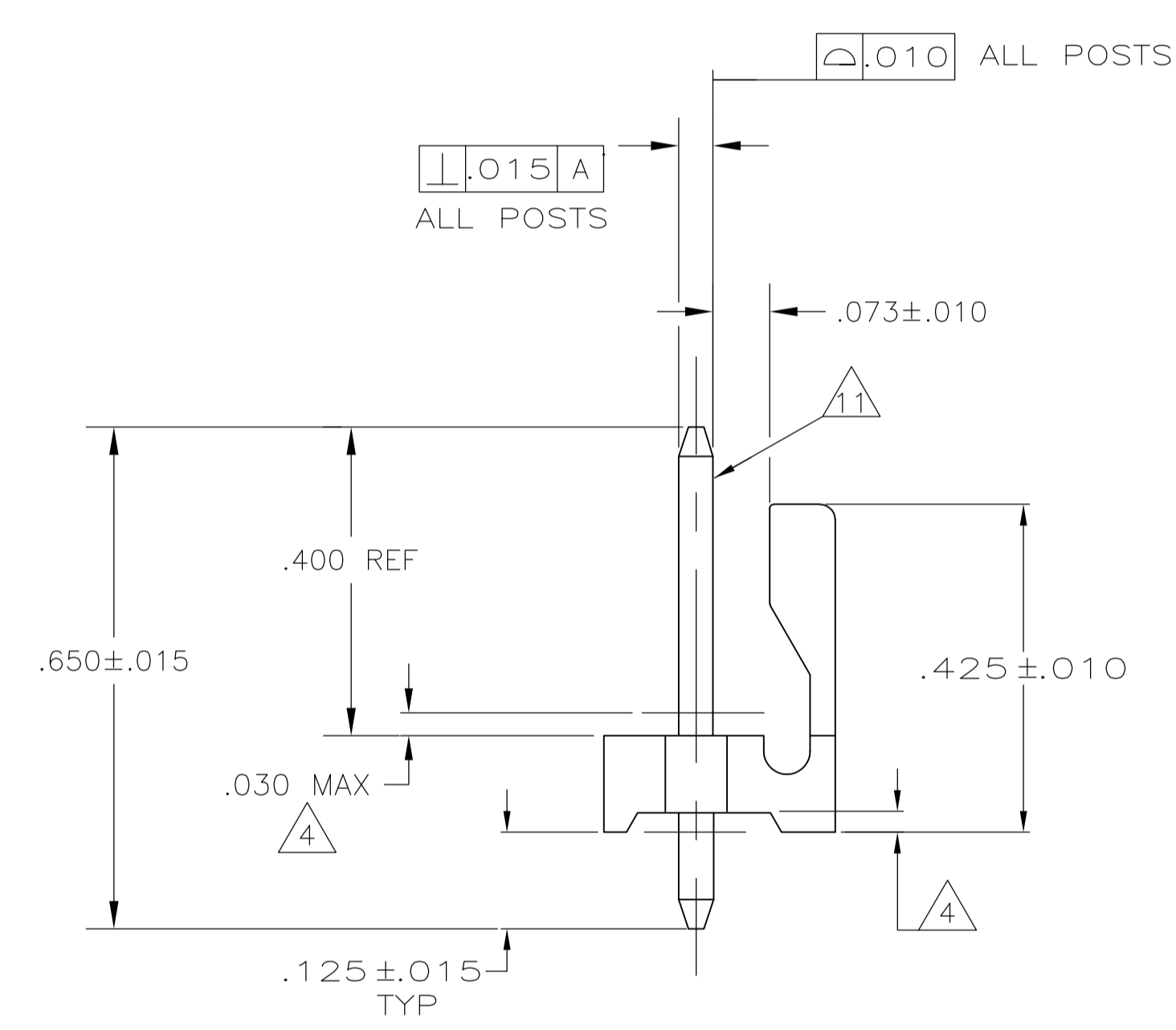
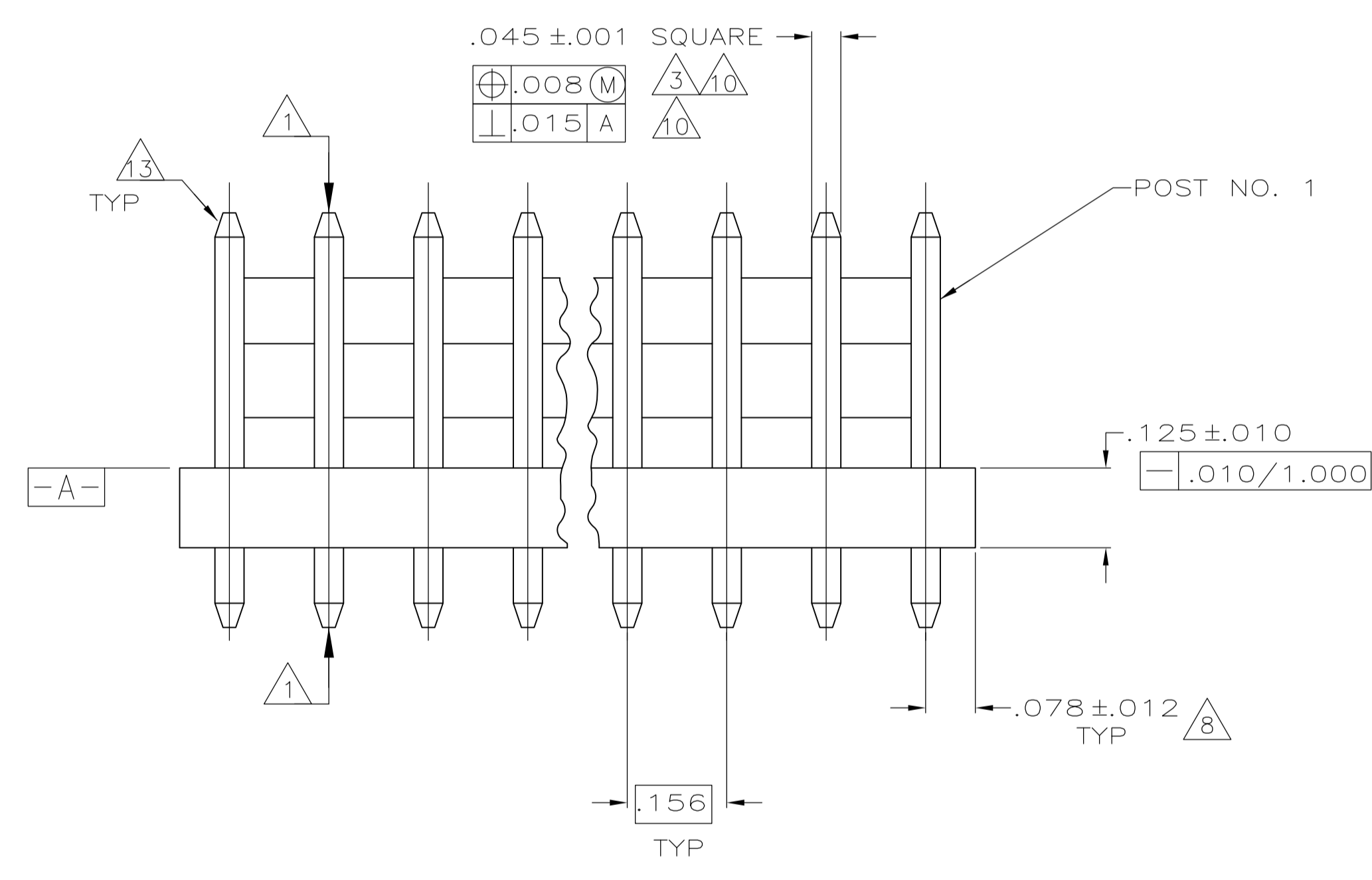
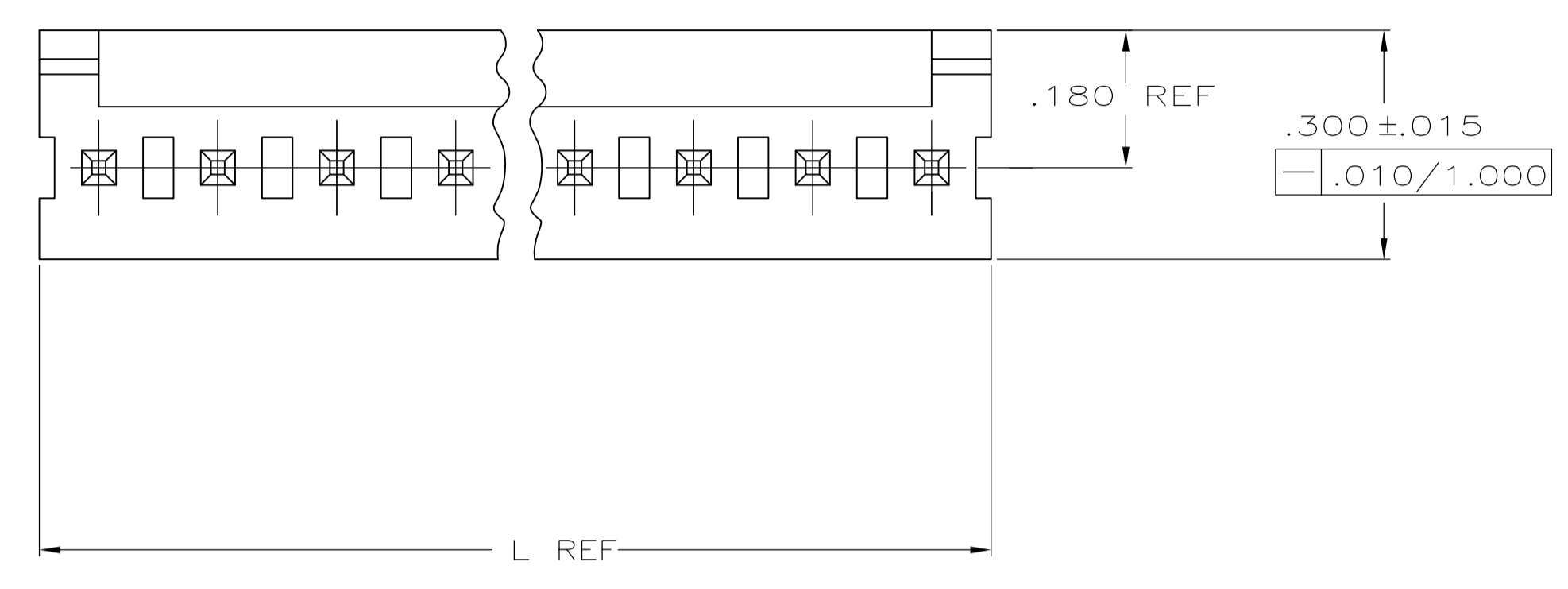

RECOMMENDED MOUNTING HOLE PATTERN FOR .063 THICK P.C. BOARD

31.70	1.248	8	3-640445-8
95.10	3.744	24	2-640445-4
91.14	3.588	23	2-640445-3
87.17	3.432	22	2-640445-2
83.21	3.276	21	2-640445-1
79.25	3.120	20	2-640445-0
75.29	2.964	19	1-640445-9
71.32	2.808	18	1-640445-8
67.36	2.652	17	1-640445-7
63.40	2.496	16	1-640445-6
59.44	2.340	15	1-640445-5
55.47	2.184	14	1-640445-4
51.51	2.028	13	1-640445-3
47.55	1.872	12	1-640445-2
43.59	1.716	11	1-640445-1
39.62	1.560	10	1-640445-0
35.66	1.404	9	640445-9
31.70	1.248	8	640445-8
27.74	1.092	7	640445-7
23.77	.936	6	640445-6
19.81	.780	5	640445-5
15.85	.624	4	640445-4
11.89	.468	3	640445-3
7.92	.312	2	640445-2
MM	[IN]	NUMBER OF POSITIONS	PART NUMBER

METRIC

.068	1.73	1.000	25.40
.065	1.65	.700	17.78
.063	1.60	.450	11.43
.060	1.52	.425	10.80
.045	1.14	.400	10.16
.030	0.76	.300	7.62
.015	0.38	.180	4.57
.012	0.30	.175	4.45
.010	0.25	.156	3.96
.008	0.20	.125	3.18
.005	0.13	.078	1.98
.003	0.08	.073	1.85
.001	0.03	.070	1.78
[IN]	MM	[IN]	MM

CONVERSION TABLE

THIS DRAWING IS A CONTROLLED DOCUMENT.

APPROVED BY: D. BOSSI

DATE: 05-NOV-2002

NAME: MTA-156 HEADER ASSEMBLY, FRICTION LOCK, STRAIGHT .045 SQUARE POST, TIN PLATED

SIZE: A1

SCALE: 5:1

SHEET: 1 of 1

REV: AA1