

REV.	DESCRIPTION	DATE	DRAWN	APPROVED
A1	DMG.REL	2016/10/7	FANG	YANG

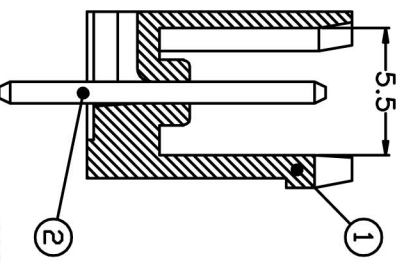
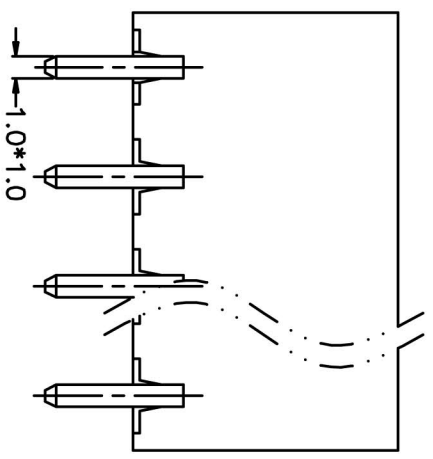
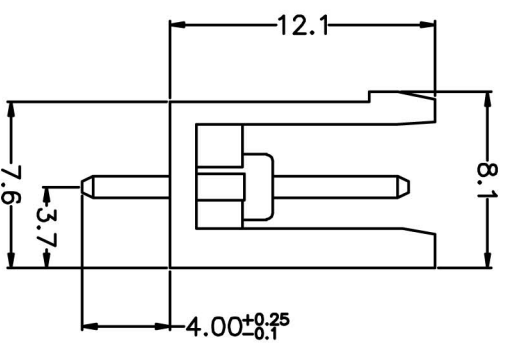
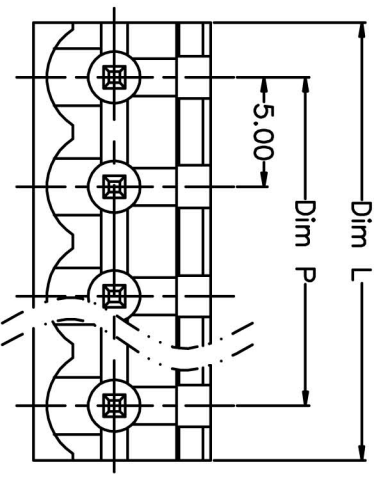

- Material
 ØHousing : PA66, UL94V-0
 ØPin header : Brass, Tin plated

- Electrical
 UL IEC
 Rated voltage : 300V 320V
 Rated current : 15A 20A
 Insulation resistance: 500MΩ/DC500V
 Withstanding Voltage : AC2000V/1min

- Mechanical
 Operating temperature: -40°C~+105°C
 Soldering temperature: 250°C±5/5sec

HOW TO ORDER

KF2EDGV-X-5.0-XXP-1 X-XXXXX

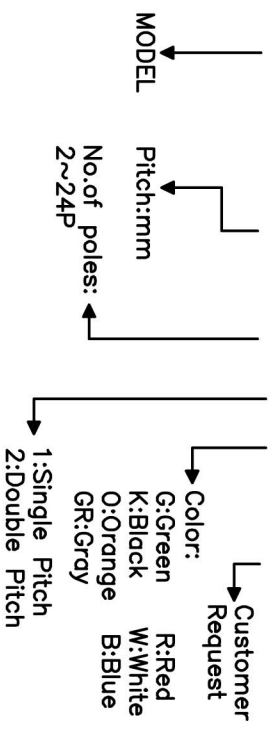

N=Number of Poles
 Dim P=(N-1)x5.00
 Dim L=Nx5.00

Poles	Dim P	Dim L
2-6P	±0.10	±0.15
7-12P	±0.20	±0.20
13-18P	±0.25	±0.30
19-24P	±0.30	±0.40

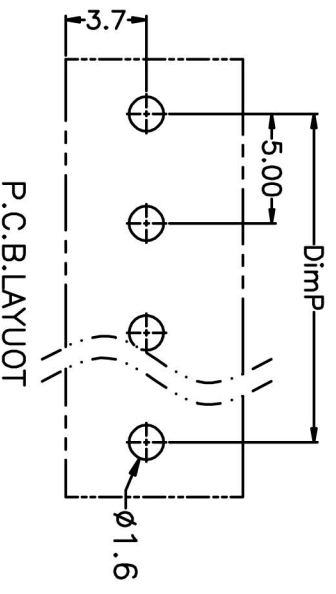

GENERAL TOLERANCE	ANGLE TOLERANCE	TOLERANCE
X, ±0.5	X', ±5'	±5
X, ±0.3	X', ±3'	±3
.XX, ±0.1	.XX', ±1'	±1

DRAWING TYPE	CUSTOMER
SCALE	1:1
DRAWING NO.	XP0012016-xxxx

PROJECTION	TITLE
UNITS mm	KF2EDGV-X-5.0-XXP
SHEET SIZE A4	SERIES KF2EDGV-X