

REV	DESCRIPTION
△	

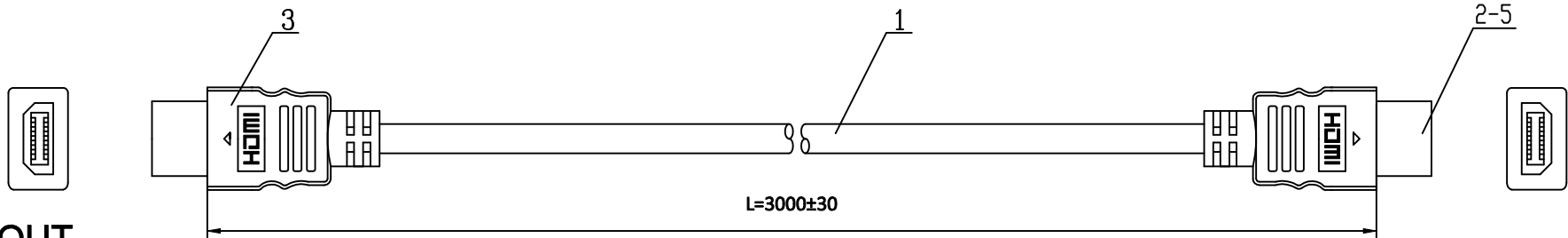

PIN OUT

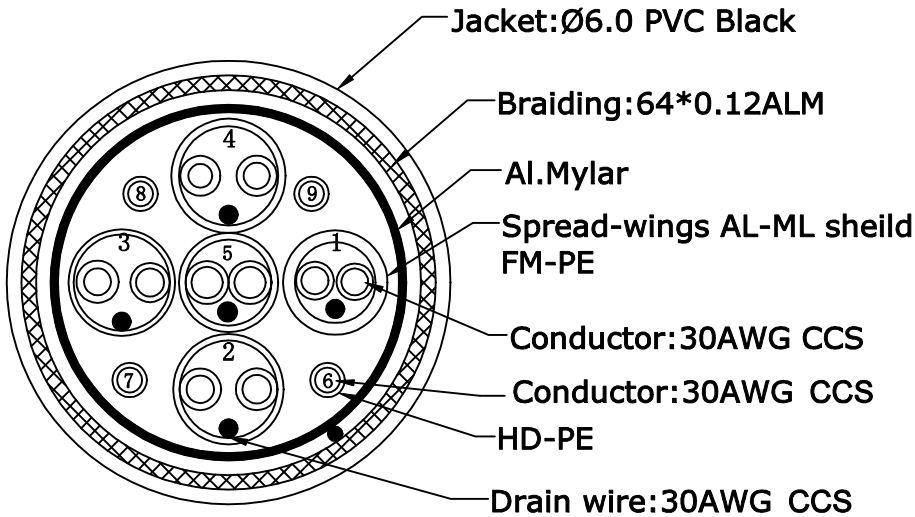
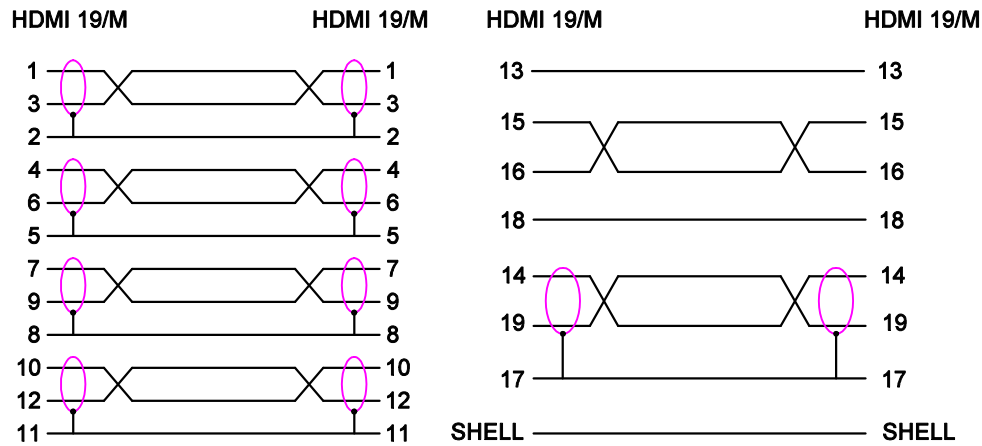

- ELECTRICAL CHARACTER:**
- 100% OPEN AND SHORT TSETING.
 - VOLTAGE: DC 300V/10ms
 - INSULATION RESISTANCE: 10M OHM(Min)
 - CONDUCTOR RESISTANCE: 2 OHM(Max)
 - SUPPORT HDMI 2.0V 4Kx2K @60Hz

5		Conductor			
4		Inner Jacket	PE		
3		MOLDING	PVC		BLACK
2		HDMI CONN.	HDMI 19P MALE Gold	2	G/Ni
1		HDMI CABLE	5P*30#+4C*30#+AB, OD:6.0mm	1	BLACK
NO.	PART NO	SPECIFICATION	MATERIAL	Q'TY	Q'TY

		DESCRIPTION	HDMI CABLE HDMI/M-HDMI/M			
		PART No.	04.001.0467			
DRAW	Gerry Gu	CONSUMER	TOP Electronic Components S.A.			
CHECK	HAN	DATE	2023/05/30	REV.	A	
APP.		SHEET	1/1	UNIT	mm	SCALE 1:1