

ENC Series

Incremental measuring wheel type Rotary encoder

■ Features

- Suitable for measuring the length or speed of target moving successively by wheel type
- The output waveform is proportional to the unit of International Measurement type (Meter or inch)
- Power supply : 5VDC, 12–24VDC ±5%



■ Application

- Packing machine, Sheet manufacturing, Textile machinery and General industrial plants.

⚠ Please read "Caution for your safety" in operation manual before using.



■ Ordering information

ENC	1	1	N	24	
Series	Output phase	Min. measuring unit	Output	Power supply	Cable
Wheel type	1 : A, B phase	1 : 1mm 2 : 1cm 3 : 1m 4 : 0.01yd 5 : 0.1yd 6 : 1yd	T : Totem pole output N : NPN open collector output V : Voltage output	5 : 5VDC ±5% 24 : 12–24VDC ±5%	No mark: Normal type (*) C: Cable outgoing connector type

* Cable length: 250mm

■ Specifications

Item		Incremental measuring wheel type of Rotary encoder		
Resolution (P/R)		Refer to resolution (Next page)		
Electrical specification	Output phase	A, B phase		
	Phase difference of output	Phase difference between A and B : $\frac{T}{4} \pm \frac{T}{8}$ (T=1 cycle of A phase)		
	Control output	Totem pole output	<ul style="list-style-type: none"> • Low \Rightarrow Load current : Max. 30mA, Residual voltage : Max. 0.4VDC • High \Rightarrow Load current : Max. 10mA, Output voltage (Power supply 5VDC) : Min. (Power supply – 2.0)VDC, Output voltage (Power supply 12–24VDC) : Min. (Power supply – 3.0)VDC 	
		NPN open collector output	Load current : Max. 30mA, Residual voltage : Max. 0.4VDC	
		Voltage output	Load current : Max. 10mA, Residual voltage : Max. 0.4VDC	
	Response time (Rise/Fall)	Totem pole output	Max. 1 μ s	
		NPN open collector output	Max. 1 μ s	
		Voltage output	Max. 1 μ s	
	Max. Response frequency	180kHz		
	Power supply	5VDC ±5% (Ripple P–P: Max. 5%), 12–24VDC ±5% (Ripple P–P: Max. 5%)		
	Current consumption	Max. 80mA (disconnection of the load)		
	Insulation resistance	Min. 100M Ω (at 500VDC mega between all terminals and case)		
	Dielectric strength	750VAC 50/60Hz for 1 minute (Between all terminals and case)		
Connection	Cable outgoing type, 250mm cable outgoing connector type			
Mechanical specification	Starting torque	Depend on coefficient of friction		
	Max. allowable revolution	(Note1) 5000rpm		
Vibration	1.5mm amplitude at frequency of 10 ~ 55Hz in each of X, Y, Z directions for 2 hours			
Shock	Max. 75G			
Ambient temperature	–10 ~ 70 $^{\circ}$ C (at non-freezing status), Storage: –25 ~ 85 $^{\circ}$ C			
Ambient humidity	35~85%RH, Storage: 35~90%RH			
Cable	ϕ 5mm, 5P, Length: 2m, Shield cable			
Protection	IP50 (IEC standard)			
Unit weight	Approx. 495g			
Approval	CE			

※ (★Note1) Max. allowable revolution \geq Max. response revolution **[**Max. response revolution (rpm) = $\frac{\text{Max. response frequency}}{\text{Resolution}} \times 60 \text{ sec}$ **]**

Incremental Measuring Wheel Type

Control output diagram

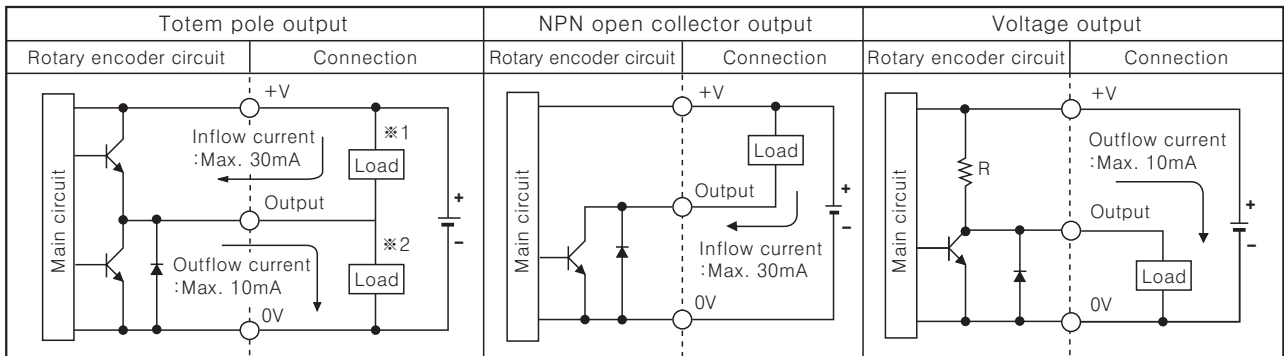

☞ The output circuit of A, B phase are same.

☞ Totem pole output can be used for NPN open collector type(*1) or voltage output type(*2).

Output waveform

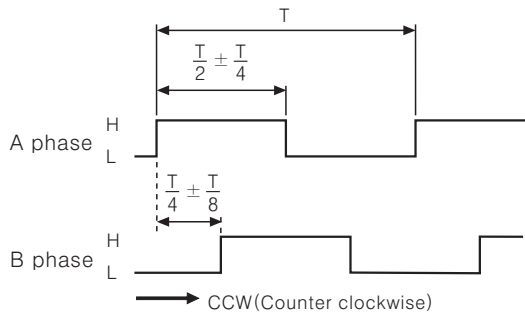

※CCW: Same revolution direction with connection F.G as below.

Resolution

No	Min. measuring unit	Moving distance per 1pulse	Gear ratio	Wheel circumference	SLIT(P/R)
1	1mm	1mm/Pulse	1 : 1	250mm	250Pulse
2	1cm	1cm/Pulse	4 : 1	250mm	100Pulse
3	1m	1m/Pulse	4 : 1	250mm	1Pulse
4	0.01yd	0.01yd/Pulse	4 : 1	228.6mm (0.25/yd)	100Pulse
5	0.1yd	0.1yd/Pulse	4 : 1	228.6mm (0.25/yd)	10Pulse
6	1yd	1yd/Pulse	4 : 1	228.6mm (0.25/yd)	1Pulse

Connections

Connector type

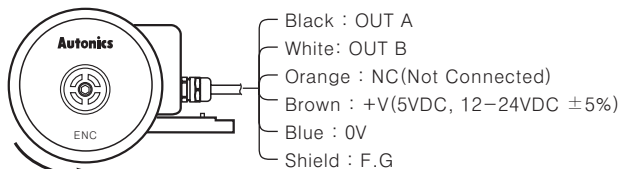

CCW(Counter clockwise)

※Unused wires must be insulated.

※The metal case and shield wire of encoder should be grounded(F.G)

Cable outgoing connector type

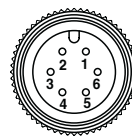

Pin No	Function	Cable color
①	OUT A	Black
②	OUT B	White
③	NC	Orange
④	+V	Brown
⑤	GND	Blue
⑥	F.G	Shield

※F.G(Field Ground) : It should be grounded separately.

Dimensions

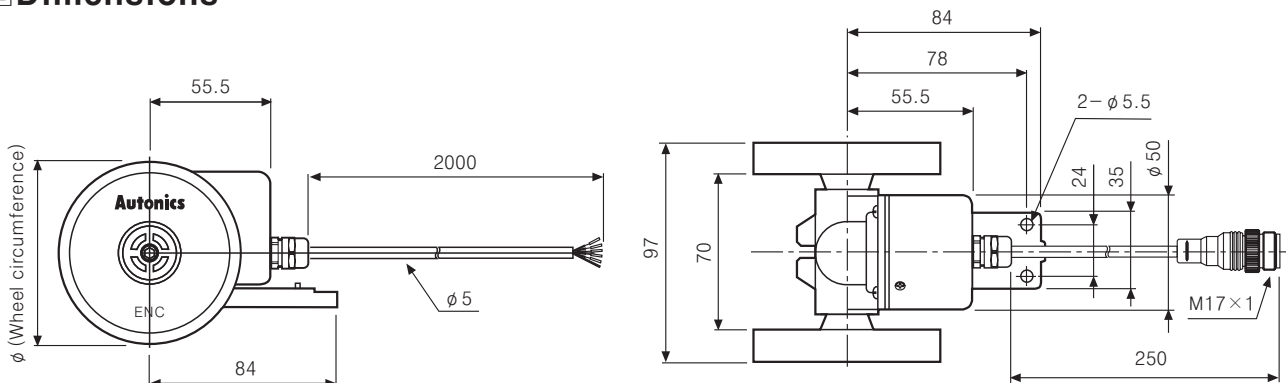

※The wheel circumference is changed according to model(ϕ), please refer to resolution chart.

※Connector cable is customizable and see M-57 for specifications.

(Unit:mm)

(A) Counter

(B) Timer

(C) Temp. controller

(D) Power controller

(E) Panel meter

(F) Tacho/ Speed/ Pulse meter

(G) Display unit

(H) Sensor controller

(I) Switching power supply

(J) Proximity sensor

(K) Photo electric sensor

(L) Pressure sensor

(M) Rotary encoder

(N) Stepping motor & Driver & Controller

(O) Graphic panel

(P) Field network device

(Q) Production stoppage models & replacement