

FOGLIO 1/2

POS.	DESCRIZIONE	DESCRIPTION	COD.	Q.TY
13	CABLAGGIO 12/24V PER PCB LED GIALLI	PCB YELLOW LEDS WIRING 12/24V	20340100	1
12	ETICHETTA PER GM034	STICKER FOR GM034	13202684	1
11	PRESSACAVO ANTISTRAPPO M16	CABLE GLAND M16	12901030	1
10	MORSETTIERA_MAMMUTH_1_POLO_mm2.5	TERMINAL BOARD 1POLE_mm2.5	12702006	3
9	CORDA GOMMA D2E5X280	GASKET	11901028	1
8	COPERCHIO PQ01 1 FORO TRASPARENTE CON LOGO	COVER PQ01 1 HOLE WITH LOGO TRANSPARENT	11710125	1
7	SUPPORTO PCB x PQ01 ILLUMINATA	PQ01 LIGHTED PCB SUPPORT	11710123	1
6	CASS Q03-Q04 1 FORO 1M16 1M20	BOX	11710078	1
5	TAPPO DIM22	PLUG DIMENSION 22	11708292	1
4	GUARNIZ PER PULSANTE DA QUADRO	PUSH BUTTON PANEL SEAL	11708202	1
3	GHIERA FILETTATA M22x1 IN ZAMA	M22x1 ZAMA LOCK NUTS	11705100	1
2	PCB CORONA LUMINOSA BIANCA PQ01	WHITE LED PCB PQ01	11702092	1
1	VITE AUTOFIL 4x30 FIL PARZ 720	SELF TAPPING SCREW 4x30	11606022	4

EDIZIONE / EDITION	DATA / DATE	MOD. / MODIFIED	FIRMA / SIGNATURE	MODIFICA / MODIFICATION	PRESCRIZIONE DI ISPEZIONE / PRESCRIPTION OF INSPECTION	LIVELLO / LEVEL	AQL
--	--	--		--	Visivo / Visual	I	2.5
--	--	--		--	Quota critica / Critique Dimension	II	1
--	--	--		--	Altre quote / Other Dimensions	I	2.5

GIOVENZANA INTERNATIONAL B.V. Strawinskylaan 1105 1077 XX Amsterdam - NL				FINITURA / FINISH --- --- MATERIALE / MATERIAL --- ---				
DENOMINAZIONE / DESCRIPTION PULSANTIERA MANUTENZIONE PQ01 12/24V LUCE BIANCA 5 LUX + TAPPO MAINTENANCE STATION PQ01 12/24V WITH 5 LUX WHITE LIGHT AND HOLE PLUG						SCALA/SCALE 0.750	DATA/DATE 04-11-2016	
DIM. INGOMBRO L x H x P 0.0 x 0.0 x 0.0				PESO / WEIGHT (g)	STAMPO / MOULD N° --	FIGURE N°/CAVITY N° 0	AVANZAMENTO/STATUS Esecutivo	
Tolleranza / Tolerance >0,5 / >.6 >6 / >.30 >30 / >.120 >120 / >.315 >315 / >.1000 >1000 / >.2000 >2000 / >.4000 >4000 / >.3.0 ±0,05 / ±0,1 ±0,1 / ±0,2 ±0,2 / ±0,5 ±0,5 / ±0,8 ±0,8 / ±1,2 ±1,2 / ±2,0 ±2,0 / ±3,0						DISEGNO / DRAWING N° GM034		REVISION -
APPROV. / APPROVED G.Triggiani G.Beretta						DIS. / DESIGNER		

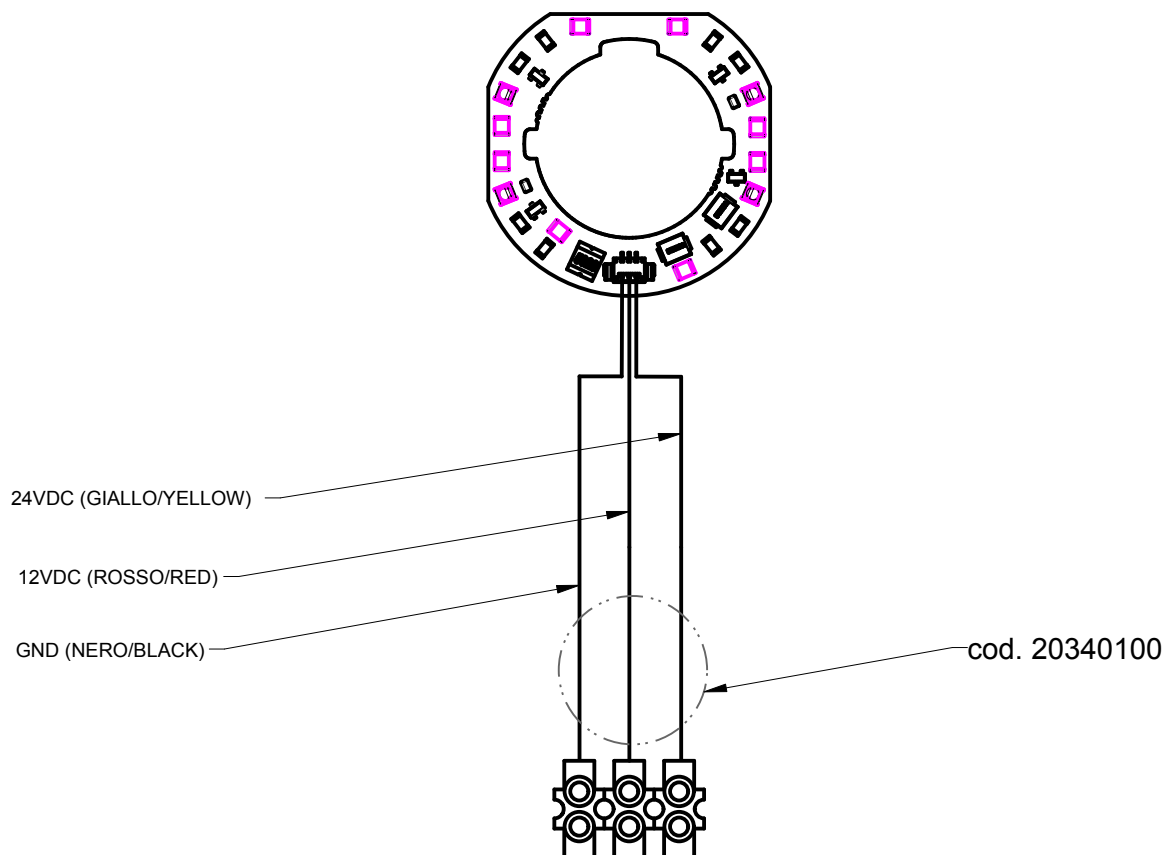

FOGLIO 2/2

EDIZIONE / EDITION	DATA / DATE	MOD. / MODIFIED	FIRMA / SIGNATURE	MODIFICA / MODIFICATION	PRESCRIZIONE DI ISPEZIONE / PRESCRIPTION OF INSPECTION	LIVELLO / LEVEL	AQL
--	--	--		--	Visivo / Visual	I	2.5
--	--	--		--	Quota critica / Critique Dimension 	II	1
--	--	--		--	Altre quote / Other Dimensions	I	2.5

GIOVENZANA INTERNATIONAL B.V. Strawinskylaan 1105 1077 XX Amsterdam - NL	FINITURA / FINISH -- --
	MATERIALE / MATERIAL -- --

DENOMINAZIONE / DESCRIPTION PULSANTIERA MANUTENZIONE PQ01 12/24V LUCE BIANCA 5 LUX + TAPPO MAINTENANCE STATION PQ01 12/24V WITH 5 LUX WHITE LIGHT AND HOLE PLUG	SCALA / SCALE 0.750	DATA / DATE 04-11-2016
	DIS. / DESIGNER G.Triggiani	

DIM. INGOMBRO L x H x P 0.0 x 0.0 x 0.0	PESO / WEIGHT (g)	STAMPO / MOULD N° --	FIGURE N° / CAVITY N° 0	AVANZAMENTO / STATUS Esecutivo	APPROV. / APPROVED G.Beretta
--	-------------------	-------------------------	----------------------------	-----------------------------------	---------------------------------

Tolleranza / Tolerance	Dimensioni Nominali / Nominal Dimensions								DISEGNO / DRAWING N° GM034	REVISION -
	>0,5	>6	>30	>120	>315	>1000	>2000	>4000		
	...6	...30	...120	...315	..1000	..2000	..4000	>4000		
	±0,05	±0,1	±0,2	±0,5	±0,8	±1,2	±2,0	±3,0		