

FOGLIO-SHEET 1/2

3°	11-12				X		
	9-10	X					
2°	7-8				X		
	5-6	X					
1°	3-4				X		
	1-2	X					
CELLA	CONT. ERINT.	1	0	2			
		POSIZIONI / POZICIOK					
X - X CONTATTO CHIUSO X - X CONTATTO CHIUSO SENZA INTERRUZIONE X ZART ERINTKEZO X - X MEGSZAKITAS NELKOLI ZART ERINTKEZO					RITORNO AUTOMATICO AUTOMATIKUS VISSZATERES		

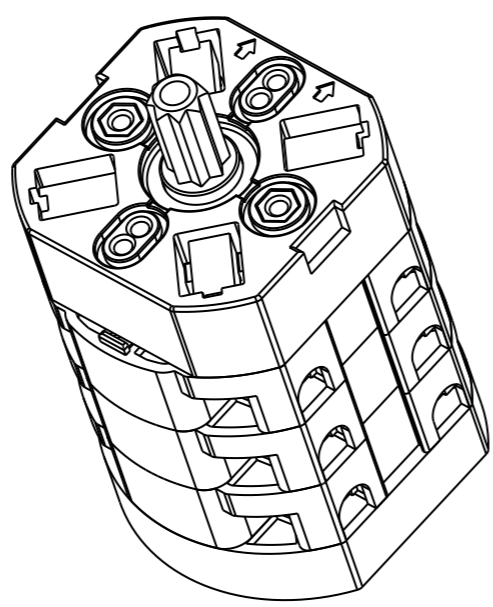

EDIZIONE / EDITION	DATA / DATE	MOD. MODIFIED	FIRMA / SIGNATURE	MODIFICA / MODIFICATION	PRESCRIZIONE DI ISPEZIONE / PRESCRIPTION OF INSPECTION	LIVELLO / LEVEL	AQL
-	-	-			Visivo / Visual	I	25
-	-	-			Quota critica / Critique Dimension	II	1
-	-	-			Altre quote / Other Dimensions	I	25
GIOVENZANA INTERNATIONAL B.V. Strawinskylaan 1105 1077 XX Amsterdam - NL				FINITURA / FINISH --- --- MATERIALE / MATERIAL --- ---			
DENOMINAZIONE / DESCRIPTION COMMUTATORE LINEA 3P NO PONTE CHANGEOVER SW. 3P NO BRIDGE						SCALA/SCALE 1:1	DATA/DATE 19/04/12
DIM. INGOMBRO L x H x P 77,8 x 48,0 x 44,0				PESO / WEIGHT 0,128	STAMPO / MOULD N° --	FIGURE N°/CAVITY N° 0	AVANZAMENTO/STATUS ESECUTIVO
Tolleranza / Tolerance >0,5 / >0,5 >6 / >6 >30 / >30 >120 / >120 >315 / >315 >1000 / >1000 >2000 / >2000 >4000 / >4000						DISEGNO / DRAWING N° P01601385	
Dimensioni Nominali / Nominal Dimensions ±0,05 / ±0,05 ±0,1 / ±0,1 ±0,2 / ±0,2 ±0,5 / ±0,5 ±0,8 / ±0,8 ±1,2 / ±1,2 ±2,0 / ±2,0 ±3,0 / ±3,0						REVISION -	
APPROV. / APPROVED T. GALIMBERTI L. PEDRONCELLI						DIS. / DESIGNER G. Galimberti T. GALIMBERTI	

SEQUENZA DI MONTAGGIO / SZERELESI SORREND

- 1) SCATOLA DI SCATTO IN
POSIZIONE DI "0"
1) KAPCSOLOFEJ "0" POZICIOBAN

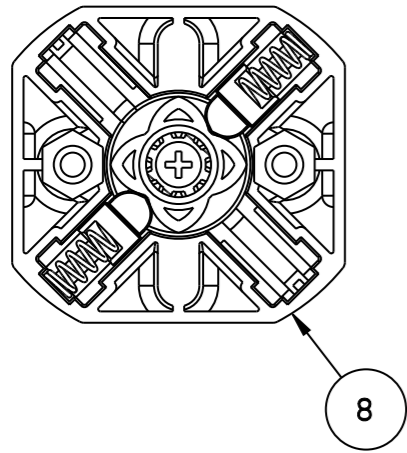

- 2) SOVRAPPORRE 1° CELLA
E INSERIRE CAMMA
2) RAHELJEZNI AZ 1° CELLAT
ES BEHELJEZNI A BUTYKOT

TACCA DI RIFERIMENTO
VONATKOZTATASI BEMETSZES

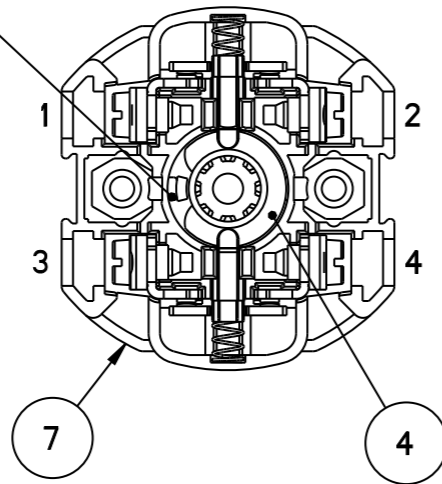

- 3) SOVRAPPORRE 2° CELLA
E INSERIRE CAMMA
3) RAHELJEZNI AZ 2° CELLAT
ES BEHELJEZNI A BUTYKOT

TACCA DI RIFERIMENTO
VONATKOZTATASI BEMETSZES

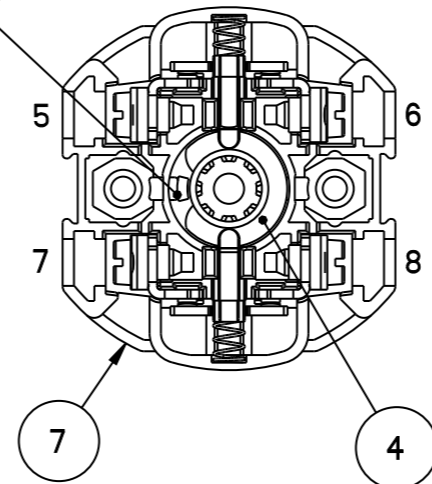

- 4) SOVRAPPORRE 3° CELLA
E INSERIRE CAMMA
4) RAHELJEZNI AZ 3° CELLAT
ES BEHELJEZNI A BUTYKOT

TACCA DI RIFERIMENTO
VONATKOZTATASI BEMETSZES

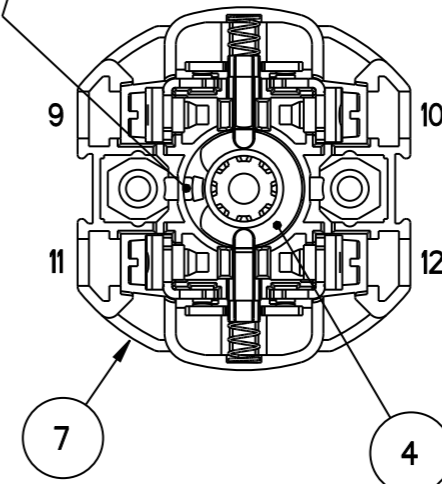

- SOVRAPPORRE FONDO PORTACONTATTI
E COMPLETARE IL FISSAGGIO
- RAHELJEZNI AZ ERINTKEZOFOGLALATOT
ES BEFEJEZNI A ROGZITEST

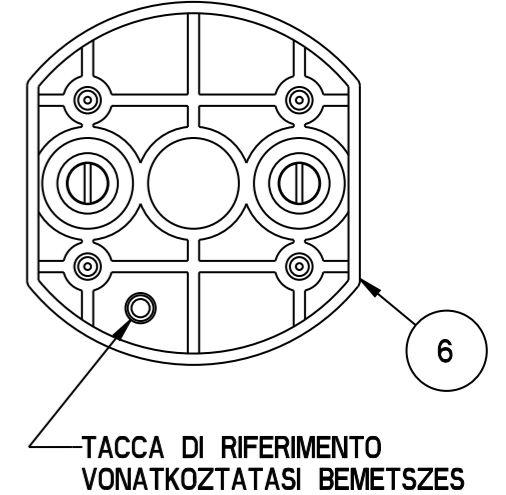

TACCA DI RIFERIMENTO
VONATKOZTATASI BEMETSZES

NB: APPLICARE GRASSO SYNGREASE-PLX SULLE
SUPERFICI DI SCORRIMENTO DELLE CAMME
NB: BEZSIROZNI A BUTYKOK SURLODASI
FELULETEIT SYNGREASE-PLX KENOANYAGGAL

FOGLIO-SHEET 2/2

8	SCATOLA SCATTO 102 90° CMT 20A M02	SWITCHING BOX 102 90° 20A SWITCH M02	28000301	1
7	CELLA 2 CONT. 1-2-3-4 CMT 20A M-B	BANK 2 CONT. 1-2-3-4 SW 20A M-B	28000051	3
6	FONDO PORTACONTATTI CMT 20A	BOTTOM PLASTIC BANK SW 20A	28000013	1
5	COLONNINA FISSAGGIO CMT40A	FIXING COLUMN SW 40A	15000042	2
4	CAMMA INC-INO COMM 1-0-2 90	CONTACT CAM INC-INO SW. 1-0-2 90°	11706119	3
3	RONDELLA PIANA 3.2X7 ZINCATA	PLANAR WASHER 3.2X7	11616001	2
2	VITE TC INTAGLIO M3x50 ZINCATA	ENGRAVED HEAD SCREW 3.2x8 ZINKED	11605071	2
1	RONDELLA ONDULATA 3.2X8 ZINCAT	WAVE SPRING WASHER 3.2x8 ZINKED	11605011	2
POS	DESCRIZIONE	DESCRIPTION	CODICE / COD	Q.ty

EDIZIONE EDITION	DATA DATE	MOD. MODIFIED	FIRMA SIGNATURE	MODIFICA / MODIFICATION	PRESCRIZIONE DI ISPEZIONE PRESCRIPTION OF INSPECTION	LIVELLO LEVEL	AQL
-	-	-		--	Visivo Visual	I	25
-	-	-		--	Quota critica Critique Dimension	II	1
-	-	-		--	Altre quote Other Dimensions	I	25
GIOVENZANA INTERNATIONAL B.V. Strawinskylaan 1105 1077 XX Amsterdam - NL				FINITURA / FINISH			
				MATERIALE / MATERIAL			
DENOMINAZIONE / DESCRIPTION						SCALA/SCALE	DATA/DATE
COMMUTATORE LINEA 3P NO PONTE CHANGEOVER SW. 3P NO BRIDGE						1:1	19/04/12
						DIS. / DESIGNER	
DIM. INGOMBRO L x H x P 77,8 x 48,0 x 44,0				PESO / WEIGHT 0,128	STAMPO / MOULD N° --	FIGURE N°/CAVITY N° 0	AVANZAMENTO/STATUS ESECUTIVO
Tolleranza						REVISION	
Dimensioni Nominali / Nominal Dimensions Tolerance						DISEGNO / DRAWING N° P01601385	
>0,5 _6 ±0,05						>6 _30 ±0,1	
>30 _120 ±0,2						>120 _315 ±0,5	
>315 _1000 ±0,8						>1000 _2000 ±1,2	
>2000 _4000 ±2,0						>4000 _±3,0	