

FOGLIO-SHEET 1/2

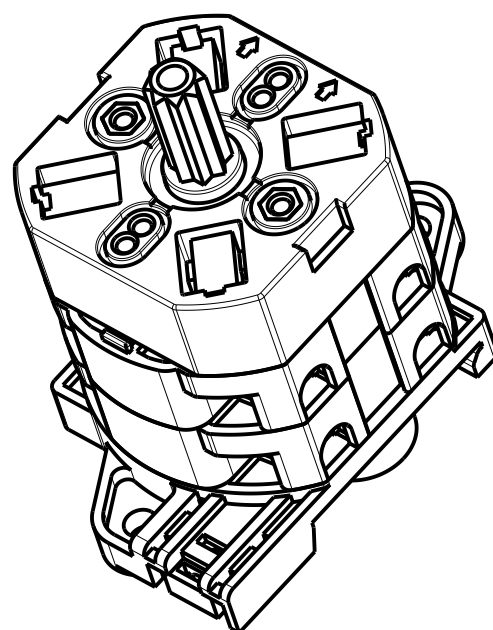

2°	7-8	X					
	5-6				X		
1°	3-4	X			X		
	1-2		X				
CELLA	CONT. ERINT.	LANDING	NORMAL	CAR			
POSIZIONI / POZICIOK							
X - X CONTATTO CHIUSO X - X CONTATTO CHIUSO SENZA INTERRUZIONE X ZART ERINTKEZO X - X MEGSZAKITAS NELKOLI ZART ERINTKEZO					RITORNO AUTOMATICO AUTOMATIKUS VISSZATERES		

EDIZIONE / EDITION	DATA / DATE	MOD. MODIFIED	FIRMA / SIGNATURE	MODIFICA / MODIFICATION	PRESCRIZIONE DI ISPEZIONE / PRESCRIPTION OF INSPECTION	LIVELLO / LEVEL	AQL
-	-	-		--	Visivo / Visual	I	25
-	-	-		--	Quota critica / Critique Dimension	II	1
-	-	-		--	Altre quote / Other Dimensions	I	25
GIOVENZANA INTERNATIONAL B.V. Strawinskylaan 1105 1077 XX Amsterdam - NL				FINITURA / FINISH -- -- MATERIALE / MATERIAL -- --			
DENOMINAZIONE / DESCRIPTION						SCALA / SCALE	DATA / DATE
COMMUTATORE SWITCH						1:1	26/02/18
DIM. INGOMBRO L x H x P 68,1 x 69,0 x 44,0						PESO / WEIGHT (g) 0,100	
STAMPO / MOULD N° --						FIGURE N° / CAVITY N° 0	
AVANZAMENTO / STATUS Esecutivo						APPROV. / APPROVED Y. COMI	
DIMENSIONI NOMINALI / NOMINAL DIMENSIONS						DISEGNO / DRAWING N° P0162807S	
Tolleranza		>0,5	>6	>30	>120	>315	>1000
Tolerance		±0,05	±0,1	±0,2	±0,5	±0,8	±1,2
						REVISION -	

SEQUENZA DI MONTAGGIO / SZERELESI SORREND

- 1) SCATOLA DI SCATTO IN POSIZIONE DI "0"  
1) KAPCSOLOFEJ "0" POZICIÓBAN

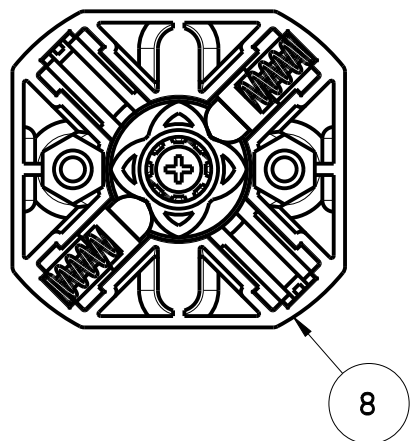

- 2) SOVRAPPORRE 1° CELLA E INSERIRE CAMMA  
2) RAHELJEZNI AZ 1° CELLAT ES BEHELJEZNI A BUTYKOT

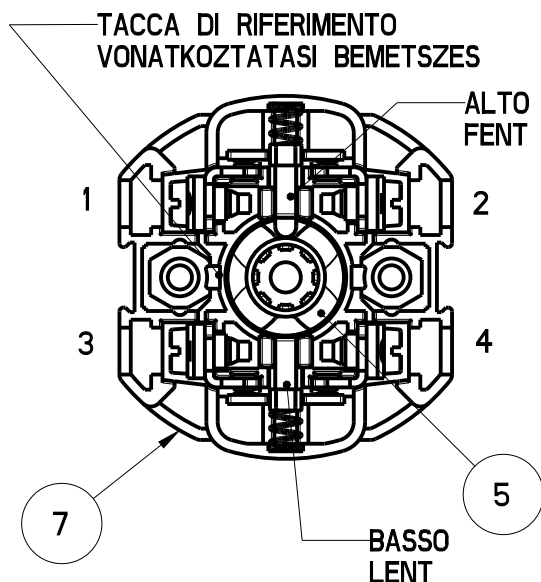

- 3) SOVRAPPORRE 2° CELLA E INSERIRE CAMMA  
3) RAHELJEZNI AZ 2° CELLAT ES BEHELJEZNI A BUTYKOT

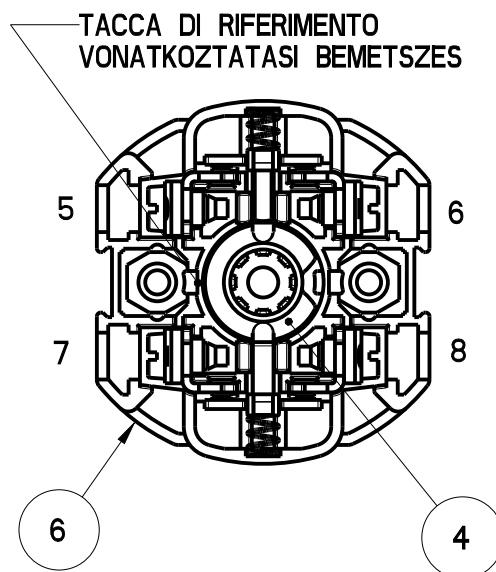

- SOVRAPPORRE FONDO PORTACONTATTI E COMPLETARE IL FISSAGGIO  
- RAHELJEZNI AZ ERINTKEZOFUGLALATOT ES BEFEJEZNI A ROGZITEST

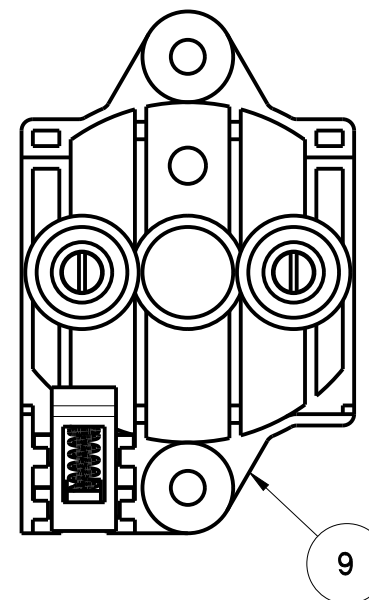

NB: APPLICARE GRASSO SYNGREASE-PLX SULLE SUPERFICI DI SCORRIMENTO DELLE CAMME  
NB: BEZSIROZNI A BUTYKOK SURLÓDASI FELÜLETEIT SYNGREASE-PLX KENOANYAGGAL

FOGLIO-SHEET 2/2

POS	DESCRIZIONE	DESCRIPTION	CODICE / COD	Q.ty
9	FONDO ASSIEME GUIDA DIN CMT 20A	BOTTOM BANK RAIL DIN SW. 20A	28002030	1
8	SCAT. SCATTO 3POS 90° CMT 20A M233	SWITCHING BOX 3POS. 90° SW. 20A M233	28000527	1
7	CELLA 2 CONTATTI C-D CMT 20A M.H	BANK 2 CONT. C-D SWITCH 20A M.H	28000059	1
6	CELLA 2 CONT. 1-2-3-4 CMT 20A M-B	BANK 2 CONT. 1-2-3-4 SW 20A M-B	28000051	1
5	CAMMA DOPPIA CMT 0431	DOUBLE CAM SW. 0431	20402184	1
4	CAMMA CONTATTI CMT 0022-2	CONTACT CAM SW. 0022-2	20402080	1
3	COLONNINA FISSAGGIO CMT40A	FIXING COLUMN SW 40A	15000042	2
2	RONDELLA ONDULATA 3.2X8 ZINCAT	WAVE SPRING WASHER 3.2x8 ZINKED	11605011	2
1	VITE TC INTAGLIO M3x35 ZINCAT	COGGING CYLINDRIC SCREW M3X25 ZINKED	11605010	2

EDIZIONE / EDITION	DATA / DATE	MOD. / MODIFIED	FIRMA / SIGNATURE	MODIFICA / MODIFICATION	PRESCRIZIONE DI ISPEZIONE / PRESCRIPTION OF INSPECTION	LIVELLO / LEVEL	AQL
-	-	-	-	-	Visivo / Visual	I	25
-	-	-	-	-	Quota critica / Critique Dimension	II	1
-	-	-	-	-	Altre quote / Other Dimensions	I	25

GIOVENZANA INTERNATIONAL B.V. Strawinskylaan 1105 1077 XX Amsterdam - NL				FINITURA / FINISH --- --- --- MATERIALE / MATERIAL --- --- ---							
DENOMINAZIONE / DESCRIPTION						SCALA/SCALE	DATA/DATE				
COMMUTATORE SWITCH						1:1	26/02/18				
						DIS. / DESIGNER G. Galimberti T. GALIMBERTI		APPROV. / APPROVED Y. COMI			
DIM. INGOMBRO L x H x P		PESO / WEIGHT (g)		STAMPO / MOULD N°	FIGURE N°/CAVITY N°	AVANZAMENTO/STATUS					
68,1 x 69,0 x 44,0		0,100		--	0	Esecutivo					
Tolleranza		Dimensioni Nominali / Nominal Dimensions						DISEGNO / DRAWING N°	REVISION		
Tolerance		>0,5 _6	>6 _30	>30 _120	>120 _315	>315 _1000	>1000 _2000	>2000 _4000	>4000	P0162807S	-
		±0,05	±0,1	±0,2	±0,5	±0,8	±1,2	±2,0	±3,0		