

DIMENSIONS ARE IN MILLIMETERS

0.5-5 = ±0.2
 5-30 = ±0.4
 30-120 = ±0.6
 120-315 = ±1
 315-1000 = ±1.6
 1000-2000 = ±2.4

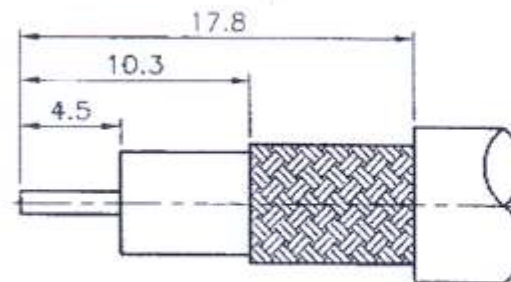

RECOMMENDED
 CABLE STRIPPING DIM'S
 (建議剝線尺寸)

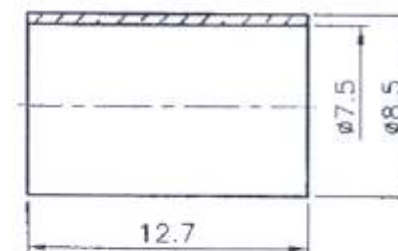
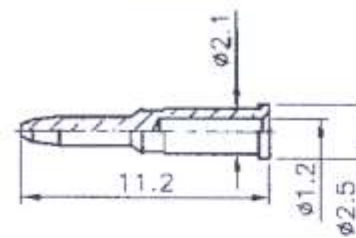

1. CRIMPED CONTACT PIN
 HEX CRIMP SIZE .068" (1.72mm)
 (中心針壓著工具)

7/16-28UNEF-2B

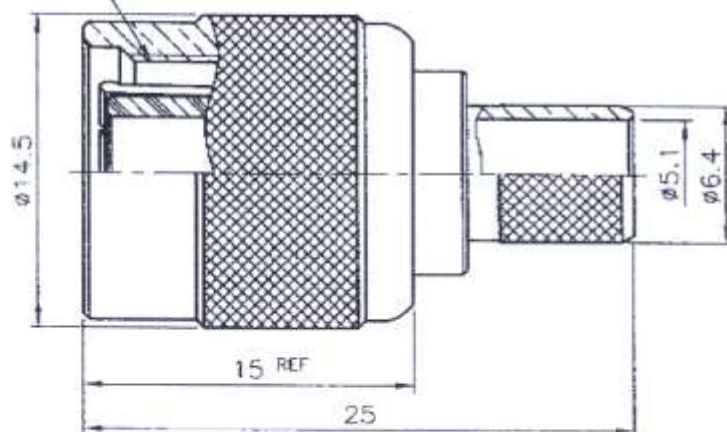

- NOTES: FINISH (PLATING THICKNESS IN MICRO-INCHES)
1. BRASS PER QQ-B-626
 2. NICKEL PL 70 MIN THICK OVER COPPER STRIKE
 3. GOLD FLUSH OVER NICKEL PL 70 MIN THICK OVER COPPER STRIKE
 4. BRASS JIS H 3250, C 2700

9	FERRULE	NOTE 4	NOTE 2	
8	CONTACT PIN	NOTE 1	NOTE 3	
7	SHELL	NOTE 1	NOTE 2	
6	GASKET	SILICONE	RED	
5	C RING	SS41	NOTE 2	
4	WASHER	DELTRIN	NATURAL	
3	WASHER	SS41	NOTE 2	
2	INSULATOR	DELTRIN	WHITE	
1	BODY	NOTE 1	NOTE 2	
NO.	DESCRIPTION	MATERIAL	FINISH	Q'TY

APPROVED BY :



Date: AUG 20 2008

RoHS COMPLIANT

UNITED AU-VI CO., LTD.

Description:

TNC MALE CRIMP RG6/U

Part No.:

V-7401C

File No.: 7411NS721CF004B

ULTIMAX[®]
 THE ULTIMATE ELECTRONIC COMPONENTS