

EMC TEST REPORT

for

Zhongshan Dianxing Electrical Appliance Industry Co., Ltd.

AC. AUTOMATIC VOLTAGE REGULATOR

Model No.: SDC-500VA, SDC-1000VA, SDC-1500VA,
SDC-2000VA, SDC-3000VA, SDC-5000VA

Prepared for : Zhongshan Dianxing Electrical Appliance Industry Co., Ltd.
Address : Anle Industrial Zone, DongFeng Town, Zhongshan,
GuangDong, China
Tel: 0760-28132828
Fax: 0760-22632721

Prepared by : Anbotek Compliance Laboratory Limited
Address : 1/F, 1/Building, SEC Industrial Park, No.4 Qianhai Road,
Nanshan District, Shenzhen, 518054, China
Tel: (86) 755-26066544
Fax: (86) 755-26014772

Report Number : 201304676E
Date of Test : Apr. 01~08, 2013
Date of Report : Apr. 09, 2013

TABLE OF CONTENTS

Description	Page
Test Report Verification	
1. GENERAL INFORMATION.....	6
1.1. Description of Device (EUT).....	6
1.2. Description of Test Facility.....	7
1.3. Measurement Uncertainty.....	7
1.4. Test Summary.....	8
2. POWER LINE CONDUCTED EMISSION TEST.....	9
2.1. Block Diagram of Test Setup.....	9
2.2. Measuring Standard.....	9
2.3. Power Line Conducted Emission Limits.....	9
2.4. EUT Configuration on Measurement.....	9
2.5. Operating Condition of EUT.....	10
2.6. Test Procedure.....	10
2.7. Test Equipment.....	10
2.8. Measuring Results.....	10
3. RADIATED EMISSION TEST.....	13
3.1. Block Diagram of Test.....	13
3.2. Measuring Standard.....	13
3.3. Radiated Emission Limits.....	13
3.4. EUT Configuration on Test.....	14
3.5. Operating Condition of EUT.....	14
3.6. Test Procedure.....	14
3.7. Test Equipment.....	14
3.8. Measuring Results.....	14
4. HARMONIC CURRENT EMISSION TEST.....	17
4.1. Block Diagram of Test Setup.....	17
4.2. Measuring Standard.....	17
4.3. Operation Condition of EUT.....	17
4.4. Test Equipment.....	17
4.5. Measuring Results.....	17
5. VOLTAGE FLUCTUATION AND FLICKER TEST.....	19
5.1. Block Diagram of Test Setup.....	19
5.2. Measuring Standard.....	19
5.3. Operation Condition of EUT.....	19
5.4. Test Equipment.....	19
5.5. Measuring Results.....	19
6. ELECTROSTATIC DISCHARGE IMMUNITY TEST.....	21
6.1. Block Diagram of Test Setup.....	21
6.2. Measuring Standard.....	21
6.3. Severity Levels and Performance Criterion.....	21
6.4. EUT Configuration.....	21
6.5. Operating Condition of EUT.....	21
6.6. Test Procedure.....	22
6.7. Test Equipment.....	22

6.8. Measuring Results.....	22
7. RF FIELD STRENGTH SUSCEPTIBILITY TEST.....	24
7.1. Block Diagram of Test.....	24
7.2. Measuring Standard.....	24
7.3. Severity Levels and Performance Criterion.....	24
7.4. EUT Configuration on Test.....	25
7.5. Operating Condition of EUT.....	25
7.6. Test Procedure.....	25
7.7. Test Equipment.....	25
7.8. Measuring Results.....	25
8. ELECTRICAL FAST TRANSIENT/BURST IMMUNITY TEST.....	27
8.1. Block Diagram of Test Setup.....	27
8.2. Measuring Standard.....	27
8.3. Severity Levels and Performance Criterion.....	27
8.4. EUT Configuration.....	27
8.5. Operating Condition of EUT.....	28
8.6. Test Procedure.....	28
8.7. Test Equipment.....	28
8.8. Measuring Results.....	28
9. SURGE IMMUNITY TEST.....	30
9.1. Block Diagram of Test Setup.....	30
9.2. Measuring Standard.....	30
9.3. Severity Levels and Performance Criterion.....	30
9.4. EUT Configuration.....	30
9.5. Operating Condition of EUT.....	31
9.6. Test Procedure.....	31
9.7. Test Equipment.....	31
9.8. Measuring Results.....	31
10. INJECTED CURRENTS SUSCEPTIBILITY TEST.....	33
10.1. Block Diagram of Test Setup.....	33
10.2. Measuring Standard.....	33
10.3. Severity Levels and Performance Criterion.....	33
10.4. EUT Configuration.....	33
10.5. Operating Condition of EUT.....	34
10.6. Test Procedure.....	34
10.7. Test Equipment.....	34
10.8. Measuring Results.....	34
11. VOLTAGE DIPS AND INTERRUPTIONS TEST.....	36
11.1. Block Diagram of Test Setup.....	36
11.2. Measuring Standard.....	36
11.3. Severity Levels and Performance Criterion.....	36
11.4. EUT Configuration.....	36
11.5. Operating Condition of EUT.....	37
11.6. Test Procedure.....	37
11.7. Test Equipment.....	37
11.8. Measuring Results.....	37
12. PHOTOGRAPHS.....	39
12.1. Photo of Power Line Conducted Emission Test.....	39
12.2. Photo of Radiated Emission Test.....	39
12.3. Photo of Flicker/Harmonic Test.....	40
12.4. Photo of RF Field Strength susceptibility Test.....	40
12.5. Photo of Electrical Fast Transient/Burst Immunity Test.....	41

12.6. Photo of Surge Immunity Test.....	41
12.7. Photo of Voltage Dips and Interruptions Test.....	42
12.8. Photo of Injected Currents Susceptibility Test.....	42
12.9. Photo of Electrostatic Discharge Test.....	43

APPENDIX I (Photos of the EUT) (3 pages)

APPENDIX II (CE Label) (1 page)

Anbotek

TEST REPORT VERIFICATION

Applicant : Zhongshan Dianxing Electrical Appliance Industry Co., Ltd.
Manufacturer : Zhongshan Dianxing Electrical Appliance Industry Co., Ltd.
EUT : AC. AUTOMATIC VOLTAGE REGULATOR
Model No. : SDC-500VA, SDC-1000VA, SDC-1500VA, SDC-2000VA,
SDC-3000VA, SDC-5000VA
Rating : AC Input: 140-260V~, 50/60Hz
AC Output: 220-230V~, 50/60Hz
Trade Mark : 

Measurement Procedure Used:

EN 55022: 2010;
EN 61000-3-2: 2006+A1: 2009+A2: 2009;
EN 61000-3-3: 2008;
EN 55024: 2010;
(IEC 61000-4-2: 2008; IEC 61000-4-3: 2006+A1: 2007; IEC 61000-4-4: 2004;
IEC 61000-4-5: 2005; IEC 61000-4-6: 2008; IEC 61000-4-11: 2004)

The device described above is tested by Anbotek Compliance Laboratory Limited to determine the maximum emission levels emanating from the device and the severe levels of the device can endure and its performance criterion. The measurement results are contained in this test report and Anbotek Compliance Laboratory Limited is assumed full of responsibility for the accuracy and completeness of these measurements. Also, this report shows that the EUT (Equipment Under Test) is technically compliant with the EN 55022, EN 61000-3-2, EN 61000-3-3, and EN 55024 requirements. The Project in IEC 61000-4-3 was tested in Shenzhen EMTEK Co., Ltd.

This report applies to above tested sample only and shall not be reproduced in part without written approval of Anbotek Compliance Laboratory Limited.

Date of Test : Apr. 01~08, 2013

Barak Ban

Prepared by : (Engineer/ Barak Ban)

Reviewer : (Project Manager/ Nancy Huang)

Tom. Chen

Approved & Authorized Signer : (Manager/Tom Chen)

1. GENERAL INFORMATION

1.1. Description of Device (EUT)

EUT : AC. AUTOMATIC VOLTAGE REGULATOR
Model Number : SDC-500VA, SDC-1000VA, SDC-1500VA, SDC-2000VA,
SDC-3000VA, SDC-5000VA
(Note: All samples are the same except the model number &
Shape of appliances, so we prepare “SDC-1000VA” for EMC
test only.)

Test Power Supply : AC 230V, 50Hz

Applicant Address : Zhongshan Dianxing Electrical Appliance Industry Co., Ltd.
Anle Industrial Zone, DongFeng Town, Zhongshan, GuangDong,
China

Manufacturer Address : Zhongshan Dianxing Electrical Appliance Industry Co., Ltd.
Anle Industrial Zone, DongFeng Town, Zhongshan, GuangDong,
China

Date of receipt : Apr. 01, 2013
Date of Test : Apr. 01~08, 2013

1.2. Description of Test Facility

The test facility is recognized, certified, or accredited by the following organizations:

FCC-Registration No.: 752021

Anbotek Compliance Laboratory Limited, EMC Laboratory has been registered and fully described in a report filed with the (FCC) Federal Loads Commission. The acceptance letter from the FCC is maintained in our files. Registration 752021, August 20, 2010.

IC-Registration No.: 8058A-1

Anbotek Compliance Laboratory Limited, EMC Laboratory has been registered and fully described in a report filed with the (IC) Industry Canada. The acceptance letter from the IC is maintained in our files. Registration 8058A-1, Feb. 22, 2013.

CNAS - LAB Code: L3503

Anbotek Compliance Laboratory Limited., Laboratory has been assessed and in compliance with CNAS/CL01: 2006 accreditation criteria for testing laboratories (identical to ISO/IEC 17025: 2005 General Requirements) for the Competence of Testing Laboratories.

Test Location

All Emissions tests were performed
Anbotek Compliance Laboratory Limited. at 1/F, 1/Building, SEC Industrial Park, No.4 Qianhai Road, Nanshan District, Shenzhen, 518054, China

1.3. Measurement Uncertainty

Radiation Uncertainty : Ur = 4.3dB

Conduction Uncertainty : Uc = 3.4dB

1.4. Test Summary

For the EUT described above. The standards used were EN 55022 for Emissions & EN 55024 for Immunity.

Table 1 : Tests Carried Out Under EN 55022: 2010

Standard	Test Items	Status
EN 55022: 2010	Power Line Conducted Emission Test (150KHz To 30MHz)	√
EN 55022: 2010	Radiated Emission Test (30MHz To 1000MHz)	√

Table 2 : Tests Carried Out Under EN 61000-3-2: 2006+A1: 2009+A2: 2009 / EN 61000-3-3: 2008

Standard	Test Items	Status
EN 61000-3-2: 2006+A1:2009+A2: 2009	Harmonic Current Test	√
EN 61000-3-3: 2008	Voltage Fluctuations and FlickerTest	√

Table 3 : Tests Carried Out Under EN 55024: 2010

Standard	Test Items	Status
EN 55024: 2010	Electrostatic Discharge immunity Test	√
EN 55024: 2010	RF Field Strength susceptibility Test	√
EN 55024: 2010	Electrical Fast Transient/Burst Immunity Test	√
EN 55024: 2010	Surge Immunity Test	√
EN 55024: 2010	Injected Currents Susceptibility Test	√
EN 55024: 2010	Magnetic Field Susceptibility Test	x
EN 55024: 2010	Voltage Dips and Interruptions Test	√

- √ Indicates that the test is applicable
- x Indicates that the test is not applicable

2. POWER LINE CONDUCTED EMISSION TEST

2.1. Block Diagram of Test Setup

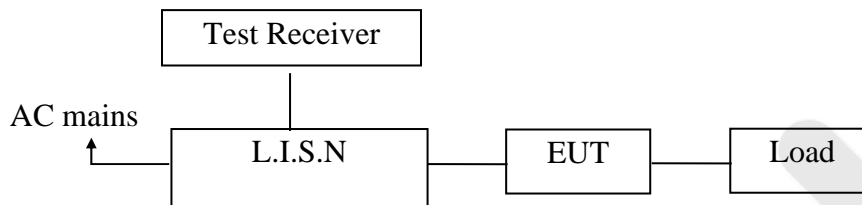

(EUT: AC. AUTOMATIC VOLTAGE REGULATOR)

2.2. Measuring Standard

EN 55022: 2010

2.3. Power Line Conducted Emission Limits

EN 55022: 2010

Power Line Conducted Emission Limits

Frequency (MHz)	Limit (dB μ V)	
	Quasi-peak Level	Average Level
0.15 ~ 0.50	66.0 ~ 56.0 *	56.0 ~ 46.0 *
0.50 ~ 5.00	56.0	46.0
5.00 ~ 30.00	60.0	50.0

NOTE1-The lower limit shall apply at the transition frequencies.
NOTE2-The limit decreases linearly with the logarithm of the frequency in the range 0.15MHz to 0.50MHz.

2.4. EUT Configuration on Measurement

The following equipments are installed on Conducted Emission Measurement to meet EN 55022 requirements and operating in a manner which tends to maximize its emission characteristics in a normal application.

2.4.1. AC. AUTOMATIC VOLTAGE REGULATOR

Model Number : SDC-1000VA
Serial Number : N/A
Applicant : Zhongshan Dianxing Electrical Appliance Industry Co., Ltd.

2.5. Operating Condition of EUT

2.5.1. Setup the EUT as shown on Section 2.1.

2.5.2. Turn on the Power of all equipments.

2.5.3. Let the EUT work and measuring it.

2.6. Test Procedure

The EUT is put on the plane 0.8 m high above the ground by insulating support and connected to the AC mains through Line Impedance Stability Network(L.I.S.N). This provided a 50ohm coupling impedance for the tested equipments. Both sides of AC line are investigated to find out the maximum conducted emission according to the EN55014-1 regulations during conducted emission measurement.

The bandwidth of the field strength meter (R&S Test Receiver ESCI) is set at 9kHz in 150kHz~30MHz.

The frequency range from 150kHz to 30MHz is investigated for AC mains.

The test results are listed in Section 2.8.

2.7. Test Equipment

The following test equipments are used during the power line conducted measurement:

Item	Equipment	Manufacturer	Model No.	Serial No.	Last Cal.	Cal. Interval
1.	EMI Receiver	Rohde & Schwarz	ESCI	100627	Nov. 12, 2012	1 Year
2.	LISN	SchwarzBeck	NSLK 8126	8126377	May 19, 2012	1 Year
3.	RF Switching Unit	Compliance Direction	RSU-M2	38303	May 19, 2012	1 Year
4.	EMI Test Software ES-K1	Rohde & Schwarz	N/A	N/A	N/A	N/A

2.8. Measuring Results

PASS.

The frequency range 150KHz to 30MHz is investigated

The test curves are shown in the following pages.

CONDUCTED EMISSION TEST DATA

EUT: AC. AUTOMATIC VOLTAGE REGULATOR M/N: SDC-1000VA
 Operating Condition: On
 Test Site: 1# Shielded Room
 Operator: Finley Li
 Test Specification: AC 230V, 50Hz
 Comment: L
 Tem:22.2°C Hum:60%

SCAN TABLE: "Voltage (150K~30M) FIN"

Short Description: 150K-30M Disturbance Voltages

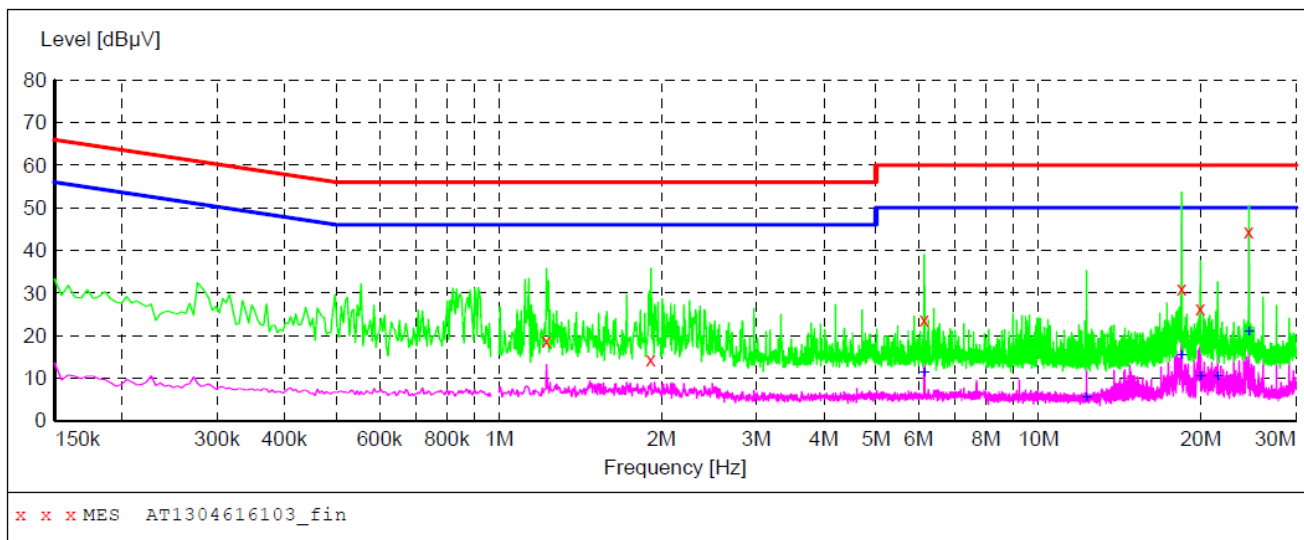

MEASUREMENT RESULT: "AT1304616103_fin"

4/2/2013 5:39PM

Frequency MHz	Level dBµV	Transd dB	Limit dBµV	Margin dB	Detector	Line	PE
1.225000	18.70	20.2	56	37.3	QP	L1	GND
1.913500	14.50	20.3	56	41.5	QP	L1	GND
6.143500	23.80	20.5	60	36.2	QP	L1	GND
18.424000	31.00	20.8	60	29.0	QP	L1	GND
19.954000	26.40	20.8	60	33.6	QP	L1	GND
24.553000	44.60	20.9	60	15.4	QP	L1	GND

MEASUREMENT RESULT: "AT1304616103_fin2"

4/2/2013 5:39PM

Frequency MHz	Level dBµV	Transd dB	Limit dBµV	Margin dB	Detector	Line	PE
6.143500	11.20	20.5	50	38.8	AV	L1	GND
12.286000	5.40	20.7	50	44.6	AV	L1	GND
18.419500	15.40	20.8	50	34.6	AV	L1	GND
19.958500	10.40	20.8	50	39.6	AV	L1	GND
21.493000	10.40	20.8	50	39.6	AV	L1	GND
24.553000	21.00	20.9	50	29.0	AV	L1	GND

CONDUCTED EMISSION TEST DATA

EUT: AC. AUTOMATIC VOLTAGE REGULATOR M/N: SDC-1000VA
 Operating Condition: On
 Test Site: 1# Shielded Room
 Operator: Finley Li
 Test Specification: AC 230V, 50Hz
 Comment: N
 Tem:22.2°C Hum:60%

SCAN TABLE: "Voltage (150K~30M) FIN"

Short Description: 150K-30M Disturbance Voltages

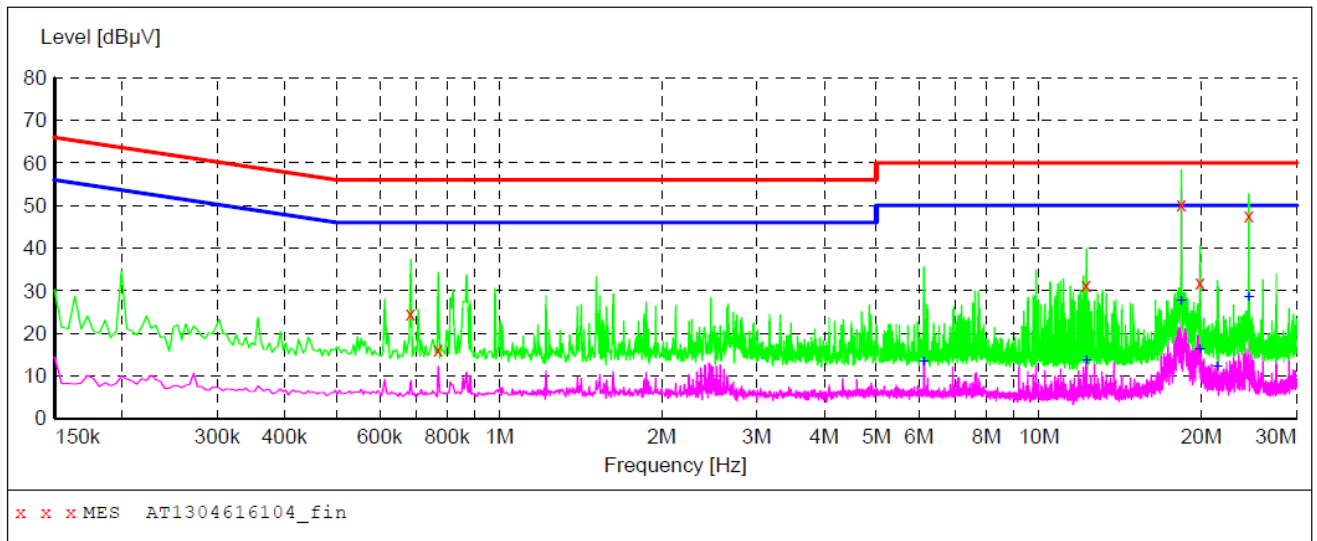

MEASUREMENT RESULT: "AT1304616104_fin"

4/2/2013 5:43PM

Frequency MHz	Level dBµV	Transd dB	Limit dBµV	Margin dB	Detector	Line	PE
0.685500	24.50	20.1	56	31.5	QP	N	GND
0.771000	16.30	20.1	56	39.7	QP	N	GND
12.245500	31.30	20.6	60	28.7	QP	N	GND
18.365500	50.40	20.8	60	9.6	QP	N	GND
19.895500	31.90	20.8	60	28.1	QP	N	GND
24.481000	47.60	20.8	60	12.4	QP	N	GND

MEASUREMENT RESULT: "AT1304616104_fin2"

4/2/2013 5:43PM

Frequency MHz	Level dBµV	Transd dB	Limit dBµV	Margin dB	Detector	Line	PE
6.125500	13.40	20.5	50	36.6	AV	N	GND
12.245500	13.60	20.6	50	36.4	AV	N	GND
18.365500	27.70	20.8	50	22.3	AV	N	GND
19.895500	16.30	20.8	50	33.7	AV	N	GND
21.425500	12.20	20.8	50	37.8	AV	N	GND
24.481000	28.40	20.8	50	21.6	AV	N	GND

3. RADIATED EMISSION TEST

3.1. Block Diagram of Test

3.1.1. Block diagram of connection between the EUT and simulators



(EUT: AC. AUTOMATIC VOLTAGE REGULATOR)

3.1.2. Block diagram of test setup (In chamber)

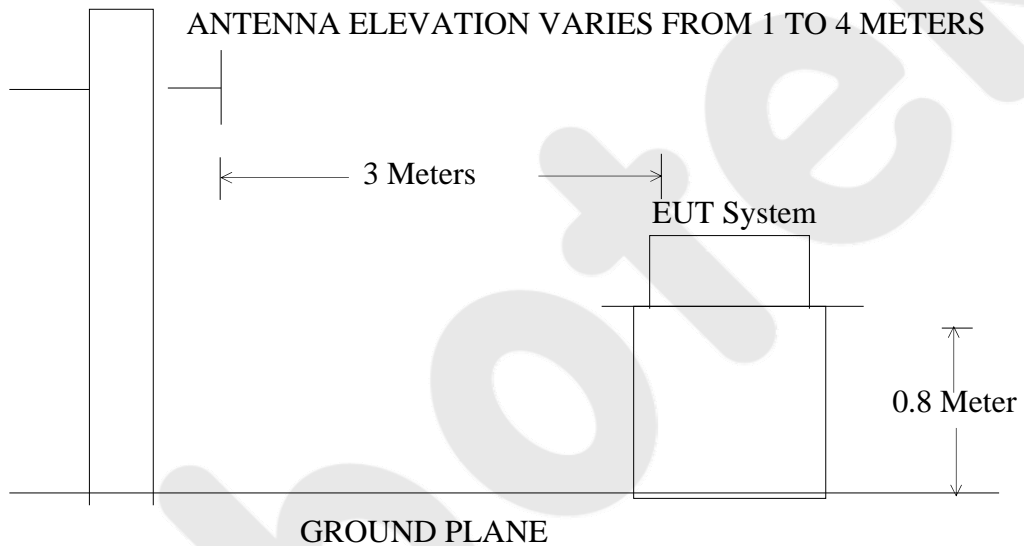

(EUT: AC. AUTOMATIC VOLTAGE REGULATOR)

3.2. Measuring Standard

EN 55022: 2010

3.3. Radiated Emission Limits

3.3.1. EN 55022: 2010

Radiated Emission Limits

All emanations from an EN 55022 device or system, including any network of conductors and apparatus connected thereto, shall not exceed the level of field strengths specified below:

FREQUENCY (MHz)	DISTANCE (Meters)	FIELD STRENGTHS LIMIT (dB μ V/m)
30 ~ 230	3	40
230 ~ 1000	3	47

Note: (1) The smaller limit shall apply at the combination point between

two frequency bands.

- (2) Distance refers to the distance in meters between the measuring instrument antenna and the closed point of any part of the EUT.

3.4. EUT Configuration on Test

The EN 55022 regulations test method must be used to find the maximum emission during radiated emission measurement.

3.5. Operating Condition of EUT

3.5.1. Turn on the Power .

3.5.2. Let the EUT work and measure it.

3.6. Test Procedure

The EUT is placed on a turn table which is 0.8 meter high above the ground. The turn table can rotate 360 degrees to determine the position of the maximum emission level. The EUT is set 3 meters away from the receiving antenna which is mounted on a antenna tower. The antenna can be moved up and down from 1 to 4 meters to find out the maximum emission level. Bilog antenna is used as a receiving antenna. Both horizontal and vertical polarization of the antenna are set on test.

The bandwidth of the Receiver (ESCI) is set at 120kHz.

The EUT is tested in 9*6*6 Chamber.

The test results are listed in Section 3.8.

3.7. Test Equipment

The following test equipments are used during radiated emission measurement:

Item	Equipment	Manufacturer	Model No.	Serial No.	Last Cal.	Cal. Interval
1.	EMI Test Receiver	Rohde & Schwarz	ESCI	100627	Nov. 12, 2012	1 Year
2.	Trilog Broadband Antenna	Schwarzbeck	VULB9163	VULB 9163-289	May 17, 2012	1 Year
3.	Pre-amplifier	Compliance Direction	PAP-0203	22008	May 19, 2012	1 Year
4.	EMI Test Software EZ-EMC	SHURPLE	N/A	N/A	N/A	N/A

3.8. Measuring Results

PASS.

The frequency range from 30MHz to 1000MHz is investigated.

The test curves are shown in the following pages.

Job No.:	AT1304616E	Polarization:	Vertical
Standard:	(RE)EN 55022_Class B_3m	Power Source:	AC 230V, 50Hz
Test item:	Radiation Test	Date:	2013/04/02
Temp.(C)/Hum.(%RH):	24.3(C)/55%RH	Time:	16:06:25
EUT:	AC. AUTOMATIC VOLTAGE REGULATOR	Test By:	Jimly Chen
Model:	SDC-1000VA	Distance:	3m
Note:	On		

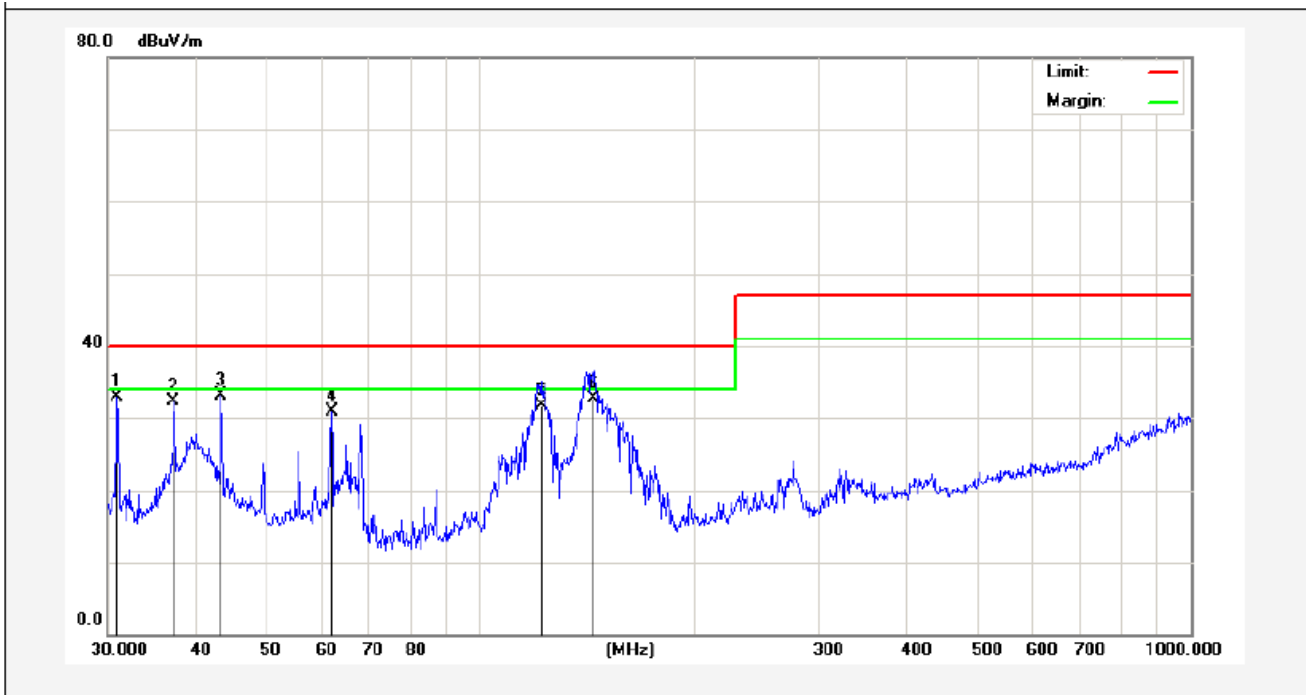

No.	Freq. (MHz)	Reading (dBuV/m)	Factor (dB/m)	Result (dBuV/m)	Limit (dBuV/)	Over Limit (dB)	Detector	Height (cm)	degree (deg)	Remark
1	30.9619	49.33	-16.44	32.89	40.00	-7.11	peak			
2	37.1550	44.81	-12.60	32.21	40.00	-7.79	peak			
3	43.3534	44.80	-11.68	33.12	40.00	-6.88	peak			
4	61.9951	47.10	-16.22	30.88	40.00	-9.12	peak			
5	121.5955	48.24	-16.57	31.67	40.00	-8.33	QP	100	0	
6	144.4306	51.22	-18.42	32.80	40.00	-7.20	QP	100	360	



Job No.:	AT1304616E	Polarization:	Horizontal
Standard:	(RE)EN 55022_Class B_3m	Power Source:	AC 230V, 50Hz
Test item:	Radiation Test	Date:	2013/04/02
Temp.(C)/Hum.(%RH):	24.3(C)/55%RH	Time:	16:09:02
EUT:	AC. AUTOMATIC VOLTAGE REGULATOR	Test By:	Jimly Chen
Model:	SDC-1000VA	Distance:	3m

Note: On

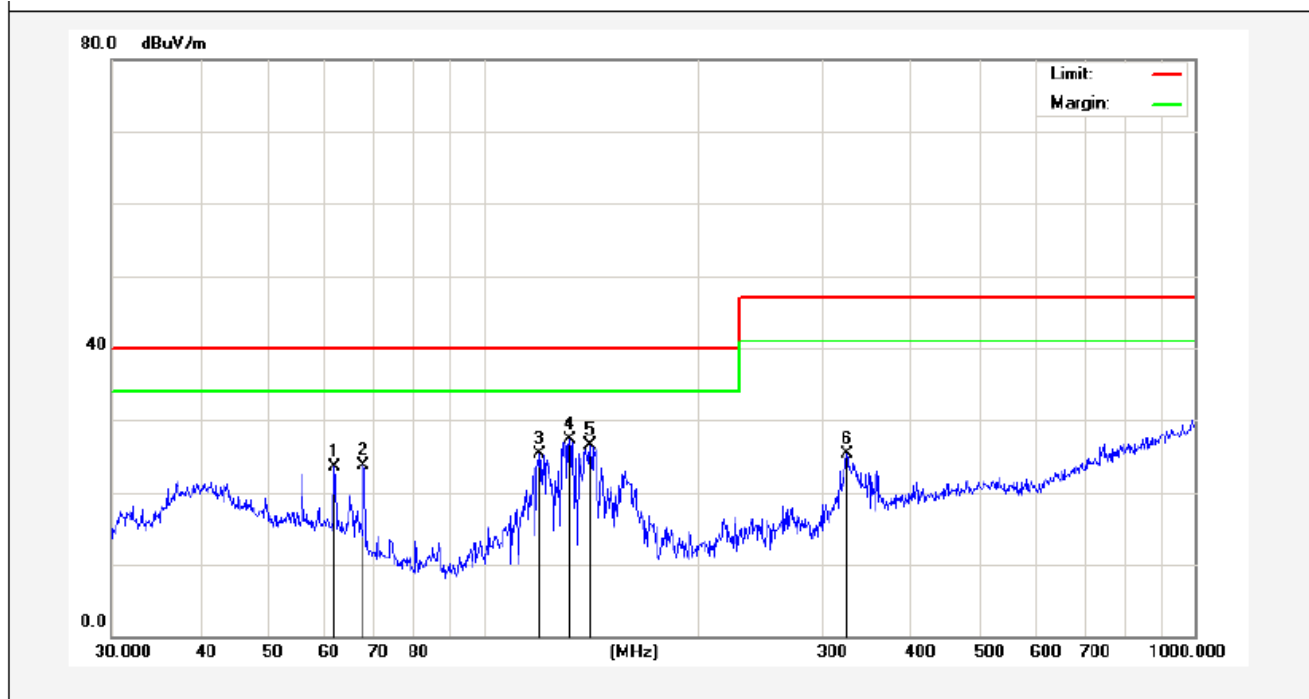

No.	Freq. (MHz)	Reading (dBuV/m)	Factor (dB/m)	Result (dBuV/m)	Limit (dBuV/)	Over Limit (dB)	Detector	Height (cm)	degree (deg)	Remark
1	61.7781	39.57	-16.13	23.44	40.00	-16.56	peak			
2	67.9129	42.34	-18.73	23.61	40.00	-16.39	peak			
3	119.8556	46.63	-21.32	25.31	40.00	-14.69	peak			
4	132.2206	50.19	-22.96	27.23	40.00	-12.77	peak			
5	141.3298	49.93	-23.47	26.46	40.00	-13.54	peak			
6	324.4561	40.25	-15.04	25.21	47.00	-21.79	peak			



4. HARMONIC CURRENT EMISSION TEST

4.1. Block Diagram of Test Setup

4.1.1. Block diagram of connection between the EUT and simulators

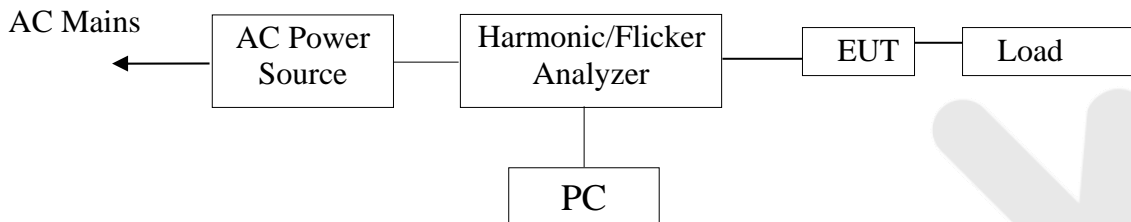

(EUT: AC. AUTOMATIC VOLTAGE REGULATOR)

4.2. Measuring Standard

EN 61000-3-2: 2006+A1: 2009+A2: 2009 Class A

4.3. Operation Condition of EUT

4.3.1. Setup the EUT as shown on Section 4.1.

4.3.2. Turn on the Power of all equipments.

4.3.3. After that, let the EUT work and measure it.

4.4. Test Equipment

The following test equipments are used during harmonic current emission measurement:

Item	Equipment	Manufacturer	Model No.	Serial No.	Last Cal.	Cal. Interval
1.	Programmable AC Power source	SOPH POWER	PAG-1050	630250	May 26, 2012	1 Year
2.	Harmonic and Flicker Analyzer	LAPLACE	AC2000A	272629	May 26, 2012	1 Year
3.	Harmonic and Flicker Test Software AC 2000A	LAPLACE	N/A	N/A	N/A	N/A

4.5. Measuring Results

PASS

The test dates are shown in the following pages.

Harmonic Current Test Result Summary (Run time)

Report Number : 201304676E
 Tested On : Apr. 03, 2013 16:05 for 150 Seconds.
 Equipment Under Test : AC. AUTOMATIC VOLTAGE REGULATOR M/N: SDC-1000VA
 Job Number : AT1304616E
 Tested by : Jimmy Zhou

Supply Voltage : 229.4 to 229.5 Vrms 327.7 Vpk Frequency : 49.98 to 50.07 Hz
 Supply Pass : Harmonic Requirements Crest Limits.

Load Power : 507.70 to 510.30 W 507.8 VA Power Factor 1.000
 Load Current : 2.2 Arms 3.2 Apk Crest Factor: 1.433

Measurement Standard : EN61000-4-7:2002
 Limits Applied : EN61000-3-2 Class A Limits Apply.

Harmonic Number	Limit Current mA	Average (filtered) mA	% Limit	max. Value (Filtered)	% Limit mA	Assessment
Fundamental :		2214.5				
2 :	1080.0	3.5	0.3	3.9	0.4	Pass
3 :	2300.0	22.0	1.0	23.5	1.0	Pass
4 :	430.0	3.3	0.8	3.4	0.8	Pass
5 :	1140.0	3.7	0.3	4.4	0.4	Pass
6 :	300.0	3.3	1.1	3.4	1.1	Pass
7 :	770.0	3.5	0.5	3.7	0.5	Pass
8 :	230.0	2.6	1.1	2.6	1.1	Pass
9 :	400.0	3.0	0.8	3.0	0.8	Pass
10 :	184.0	1.7	0.9	1.7	0.9	Pass
11 :	330.0	1.5	0.5	1.6	0.5	Pass
12 :	153.3	1.0	0.7	1.0	0.7	Pass
13 :	210.0	1.4	0.7	1.4	0.7	Pass
14 :	131.4	0.5	0.4	0.5	0.4	Pass
15 :	150.0	0.6	0.4	0.7	0.5	Pass
16 :	115.0	0.1	0.1	0.1	0.1	Pass
17 :	132.3	0.7	0.5	0.7	0.5	Pass
18 :	102.2	0.3	0.3	0.3	0.3	Pass
19 :	118.4	0.5	0.4	0.5	0.4	Pass
20 :	92.0	0.3	0.3	0.3	0.3	Pass
21 :	107.1	0.8	0.7	0.8	0.7	Pass
22 :	83.6	0.4	0.5	0.3	0.4	Pass
23 :	97.8	0.3	0.3	0.3	0.3	Pass
24 :	76.7	0.4	0.5	0.3	0.4	Pass
25 :	90.0	0.5	0.6	0.5	0.6	Pass
26 :	70.8	0.4	0.6	0.3	0.4	Pass
27 :	83.3	0.8	1.0	0.8	1.0	Pass
28 :	65.7	0.4	0.6	0.3	0.5	Pass
29 :	77.6	0.1	0.1	0.1	0.1	Pass
30 :	61.3	0.3	0.5	0.3	0.5	Pass
31 :	72.6	0.3	0.4	0.3	0.4	Pass
32 :	57.5	0.2	0.3	0.1	0.2	Pass
33 :	68.2	0.4	0.6	0.3	0.4	Pass
34 :	54.1	0.0	-	0.0	-	Pass
35 :	64.3	0.3	0.5	0.3	0.5	Pass
36 :	51.1	0.1	0.2	0.1	0.2	Pass
37 :	60.8	0.5	0.8	0.5	0.8	Pass
38 :	48.4	0.1	0.2	0.1	0.2	Pass
39 :	57.7	0.5	0.9	0.5	0.9	Pass
40 :	46.0	0.1	0.2	0.0	-	Pass
21 - 39 :	251.4	1.5	0.6	1.7	0.7	-

5. VOLTAGE FLUCTUATION AND FLICKER TEST

5.1. Block Diagram of Test Setup

5.1.1. Block diagram of connection between the EUT and simulators

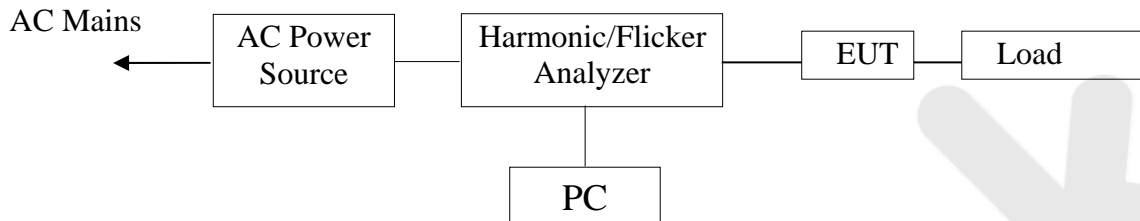

(EUT: AC. AUTOMATIC VOLTAGE REGULATOR)

5.2. Measuring Standard

EN 61000-3-3: 2008

5.3. Operation Condition of EUT

5.3.1. Setup the EUT as shown on Section 5.1.

5.3.2. Turn on the Power of all equipments.

5.3.3. After that, let the EUT work and measure it.

5.4. Test Equipment

The following test equipments are used during the voltage fluctuations and flicker measurement:

Item	Equipment	Manufacturer	Model No.	Serial No.	Last Cal.	Cal. Interval
1.	Programmable AC Power source	SOPH POWER	PAG-1050	630250	May 26, 2012	1 Year
2.	Harmonic and Flicker Analyzer	LAPLACE	AC2000A	272629	May 26, 2012	1 Year
3.	Harmonic and Flicker Test Software AC 2000A	LAPLACE	N/A	N/A	N/A	N/A

5.5. Measuring Results

PASS

The test dates are shown in the following pages.

Flicker Test Summary per EN/IEC61000-3-3 (Run time)

HA-PC Link Plus. Software v2.02. Firmware v2.81
 Report Number : 201304676E
 Tested On : Apr. 03, 2013 16:08 for 600 Seconds.
 Equipment Under Test : AC. AUTOMATIC VOLTAGE REGULATOR
 Job Number : AT1304616E
 Tested by : Jimmy Zhou

Supply Voltage : 229.4 to 229.5 Vrms 327.7 Vpk Frequency : 50.00 Hz
 Load Current : 2.2 Arms 3.2 Apk Crest Factor: 1.432

Test Method: EN61000-3-3:2008

Voltage Variations :

Highest Level:	-0.10%	
Lowest Level:	-0.47%	
d(max):	0.37%	PASS
Highest d(t) of 500ms:	0.00%	PASS
Present d(t) over 3.33%:	0.00 Seconds	
Longest d(t) over 3.33%:	0.00 Seconds	
Highest Steady State:	-0.30%	
Lowest Steady State:	-0.30%	
Max d(c) Between Adjacent:	0.00%	PASS
Max d(c) Between Any:	0.00%	
Short Term Flicker Pst:	0.32	PASS

Flicker Results :

Pst Classifier	Pst	Plt Calculation Interval
Duration	Flicker	Pst
0.1%	3.34	
0.7%	0.00	
1.0%	0.00	
1.5%	0.00	
2.2%	0.00	
3%	0.00	
4%	0.00	
6%	0.00	
8%	0.00	
10%	0.00	
13%	0.00	
17%	0.00	
30%	0.00	
50%	0.00	
80%	0.00	

6. ELECTROSTATIC DISCHARGE IMMUNITY TEST

6.1. Block Diagram of Test Setup

6.1.1. Block diagram of connection between the EUT and simulators



(EUT: AC. AUTOMATIC VOLTAGE REGULATOR)

6.1.2. Block diagram of test setup

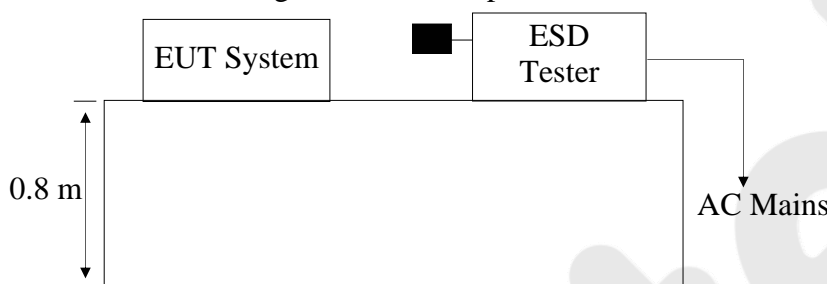

(EUT: AC. AUTOMATIC VOLTAGE REGULATOR)

6.2. Measuring Standard

EN 55024: 2010

IEC 61000-4-2: 2008

Severity Level: 3 / Air Discharge: ± 8 kV Level: 2 / Contact Discharge: ± 4 kV

6.3. Severity Levels and Performance Criterion

6.3.1. Severity level

Level	Test Voltage Contact Discharge (kV)	Test Voltage Air Discharge (kV)
1.	± 2	± 2
2.	± 4	± 4
3.	± 6	± 8
4.	± 8	± 15
X	Special	Special

6.3.2. Performance criterion: **B**

6.4. EUT Configuration

The configuration of EUT are listed in Section 2.4.1.

6.5. Operating Condition of EUT

Same as conducted emission measurement, which is listed in Section 2.5 except the test set up replaced by Section 6.1.

6.6. Test Procedure

6.6.1. Air Discharge:

This test is done on a non-conductive surface. The round discharge tip of the discharge electrode shall be approached as fast as possible to touch the EUT. After each discharge, the discharge electrode shall be removed from the EUT. The generator is then re-triggered for a new single discharge and repeated 100 times for each pre-selected test point. This procedure shall be repeated until all the air discharge completed

6.6.2. Contact Discharge:

All the procedure shall be same as Section 6.6.1. except that the tip of the discharge electrode shall touch the EUT before the discharge switch is operated.

6.6.3. Indirect discharge for horizontal coupling plane

At least 50 single discharges shall be applied to the horizontal coupling plane, at points on each side of the EUT. The discharge electrode positions vertically at a distance of 0.1m from the EUT and with the discharge electrode touching the coupling plane.

6.6.4. Indirect discharge for vertical coupling plane

At least 50 single discharge shall be applied to the center of one vertical edge of the coupling plane. The coupling plane, of dimensions 0.5m X 0.5m, is placed parallel to, and positioned at a distance of 0.1m from the EUT. Discharges shall be applied to the coupling plane, with this plane in sufficient different positions that the four faces of the EUT are completely illuminated.

6.7. Test Equipment

The following test equipments are used during the Electrostatic Discharge measurement:

Item	Equipment	Manufacturer	Model No.	Serial No.	Last Cal.	Cal. Interval
1.	ESD Simulators	KIKUSUI	KES4021	LJ003477	May 25, 2012	1 Year

6.8. Measuring Results

PASS

Please refer to the following pages

Electrostatic Discharge Test Results

Anbotek Compliance Laboratory Limited

Applicant : Zhongshan Dianxing Electrical Appliance Industry Co., Ltd.	Test Date : Apr. 03, 2013	
EUT : AC. AUTOMATIC VOLTAGE REGULATOR	Temperature : 25°C	
M/N : SDC-1000VA	Humidity : 54%	
Air discharge : ±8.0kV	Criterion : B	
Contact discharge: ±4.0kV	Test Engineer: Jimmy zhou	
Test Mode : On		
Location	Kind A-Air Discharge C-Contact Discharge	Result
Slot of the EUT 16 points	A	PASS
Others 16 points	A	PASS
Metal surface of EUT 12 points	C	PASS
Function Keys 2 points	A	PASS
Switch 1 points	A	PASS
Screen 2 points	A	PASS
Screws 8 points	C	PASS
HCP 8 points	C	PASS
VCP of front 8 points	C	PASS
VCP of rear 8 points	C	PASS
VCP of left 8 points	C	PASS
VCP of right 8 points	C	PASS

Note:

Anbotek

7. RF FIELD STRENGTH SUSCEPTIBILITY TEST

7.1. Block Diagram of Test

7.1.1. Block diagram of connection between the EUT and simulators

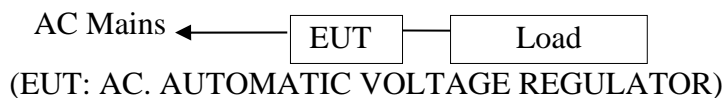

7.1.2. Block diagram of RS test setup

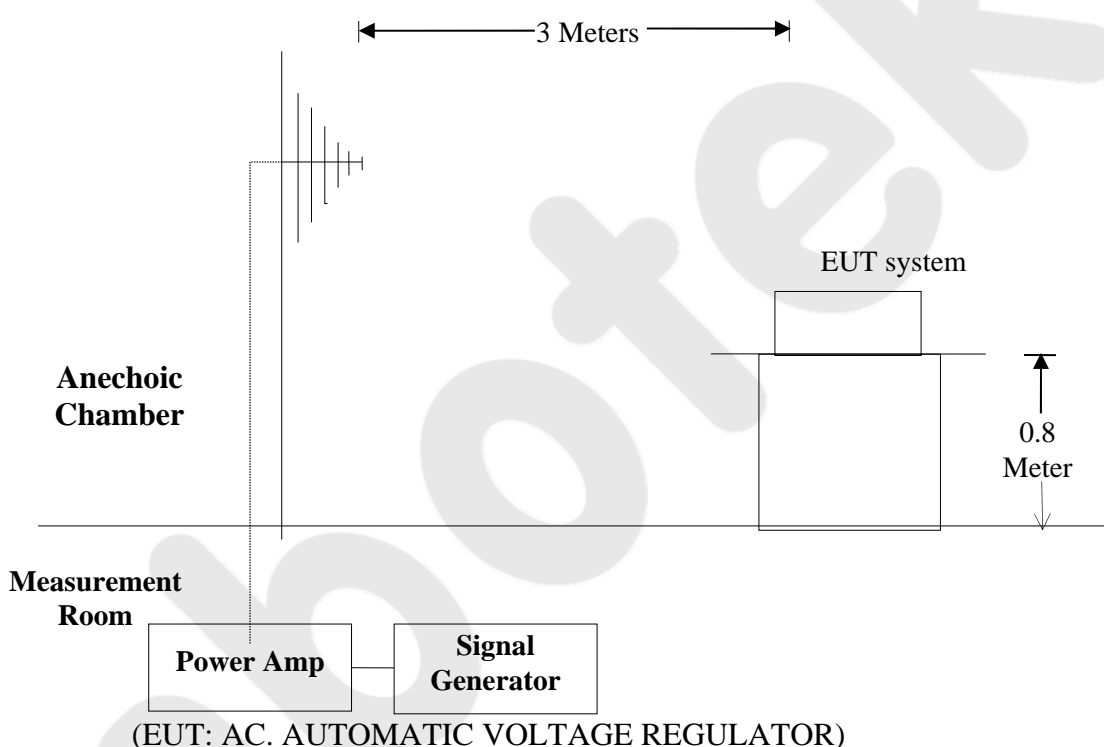

7.2. Measuring Standard

EN 55024: 2010
IEC 61000-4-3: 2006+A1: 2007
Severity Level: 2, 3V / m

7.3. Severity Levels and Performance Criterion

7.3.1. Severity Levels

Level	Field Strength V/m
1.	1
2.	3
3.	10
X	Special

7.3.2. Performance Criterion: A

7.4. EUT Configuration on Test

The configuration of the EUT is same as Section 2.4.1.

7.5. Operating Condition of EUT

Same as conducted emission measurement which is listed in Section 2.5. except the test setup replaced as Section 7.1.

7.6. Test Procedure

The EUT are placed on a table which is 0.8 meter high above the ground. The EUT is set 3 meters away from the transmitting antenna which is mounted on an antenna tower. Both horizontal and vertical polarization of the antenna are set on test. Each of the four sides of the EUT must be faced this transmitting antenna and measured individually.

In order to judge the EUT performance, a CCD camera is used to monitor its screen. All the scanning conditions are as following:

Condition of Test	Remark
1. Fielded Strength	3V/m (Severity Level 2)
2. Radiated Signal	Unmodulated
3. Scanning Frequency	80-1000MHz
4. Sweep time of radiated	0.0015 Decade/s
2. Dwell Time	1 Sec.

7.7. Test Equipment

The following test equipments are used during the R/S (Shenzhen EMTEK) measurement:

Item	Equipment	Manufacturer	Model No.	Serial No.	Last Cal.	Cal. Interval
1.	RF Power Meter. Dual Channel	BOONTON	4232A	10539	May 29, 2012	1 year
2.	50ohm Diode Power Sensor	BOONTON	51011EMC	34236/34238	May 29, 2012	1 year
3.	Broad-Band Horn Antenna	SCHWARZBECK	BBHA9120 L3F	332	May 29, 2012	1 year
4.	Power Amplifier	PRANA	AP32MT215	N/A	May 29, 2012	1 year
5.	Power Amplifier	MILMEGA	AS0102-55	N/A	May 29, 2012	1 year
6.	Signal Generator	AEROFLEX	2023B	N/A	May 29, 2012	1 year
7.	Field Strength Meter	HOLADAY	HI-6005	N/A	May 29, 2012	1 year
8.	RS232 Fiber Optic Modem	HOLADAY	HI-4413P	N/A	May 29, 2012	1 year
9.	Log.-Per. Antenna	SCHWARZBECK	VULP 9118E	N/A	May 29, 2012	1 year

7.8. Measuring Results

PASS.

Please refer to the following page.

RF Field Strength Susceptibility Test Results

Anbotek Compliance Laboratory Limited

Applicant : Zhongshan Dianxing Electrical Appliance Industry Co., Ltd. <hr/> EUT : AC. AUTOMATIC VOLTAGE REGULATOR <hr/> M/N : SDC-1000VA <hr/> Field Strength : 3 V/m <hr/> Test Mode : On	Test Date : Apr. 03, 2013 <hr/> Temperature : 25°C <hr/> Humidity : 54% <hr/> Criterion : A <hr/> Test Engineer : Jimmy Zhou <hr/> Frequency Range: 80 MHz to 1000 MHz			
Modulation: <input type="checkbox"/> None <input type="checkbox"/> Pulse <input checked="" type="checkbox"/> AM 1KHz 80%				
	Frequency Rang 1: 80~ 1000MHz	Frequency Rang 2:		
Steps	# / %	# / %		
	Horizontal	Vertical	Horizontal	Vertical
Front	PASS	PASS		
Right	PASS	PASS		
Rear	PASS	PASS		
Left	PASS	PASS		
Note: The Project was tested in Shenzhen EMTEK Co., Ltd.				

8. ELECTRICAL FAST TRANSIENT/BURST IMMUNITY TEST

8.1. Block Diagram of Test Setup

8.1.1. Block diagram of connection between the EUT and simulators

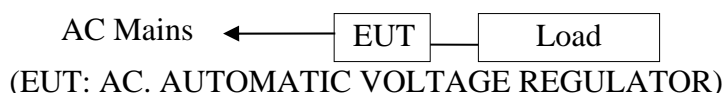

8.1.2. EFT Test Setup

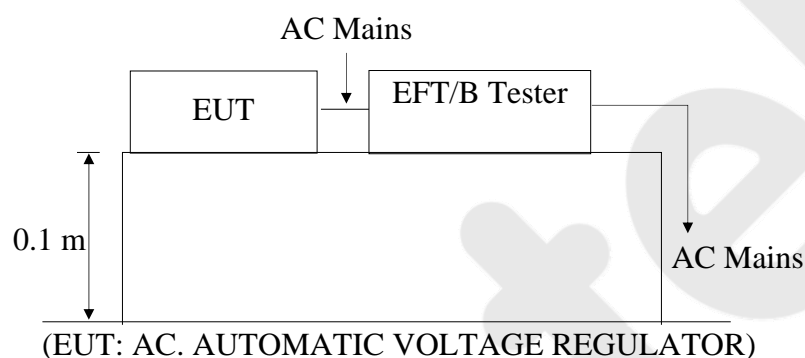

8.2. Measuring Standard

EN 55024: 2010
IEC 61000-4-4: 2004
Severity Level, Level 2: 1.0kV

8.3. Severity Levels and Performance Criterion

8.3.1. Severity level

Open Circuit Output Test Voltage $\pm 10\%$		
Level	On Power Supply Lines	On I/O (Input/Output) Signal data and control lines
1.	0.5 kV	0.25 kV
2.	1 kV	0.5 kV
3.	2 kV	1 kV
4.	4 kV	2 kV
X	Special	Special

8.3.2. Performance criterion: **B**

8.4. EUT Configuration

The configuration of EUT are listed in Section 2.4.1.

8.5. Operating Condition of EUT

Same as conducted emission measurement, which is listed in Section 2.5, except the test set up replaced by Section 8.1.

8.6. Test Procedure

The EUT is put on the table which is 0.1 meter high above the ground. This reference ground plane shall project beyond the EUT by at least 0.1m on all sides and the minimum distance between EUT and all other conductive structure, except the ground plane beneath the EUT, shall be more than 0.5m.

8.6.1. For input and output AC Power ports:

The EUT is connected to the Power mains by using a coupling device which couples the EFT interference signal to AC Power lines. Both polarities of the test voltage should be applied during compliance test and the duration of the test is 2 mins.

8.6.2. For signal lines and control lines ports:

No I/O ports. It's unnecessary to test.

8.6.3. For DC output line ports:

It's unnecessary to test.

8.7. Test Equipment

The following test equipments are used during the Electrical Fast Transient /Burst Immunity measurement:

Item	Equipment	Manufacturer	Model No.	Serial No.	Last Cal.	Cal. Interval
1.	EFT Generator	EMPEK	EFT-4040B	0430928N	May 19, 2012	1 Year

8.8. Measuring Results

PASS.

Please refer to the following page.

Electrical Fast Transient/Burst Test Results

Anbotek Compliance Laboratory Limited

Applicant : <u>Zhongshan Dianxing Electrical Appliance Industry Co., Ltd.</u>			
EUT : <u>AC. AUTOMATIC VOLTAGE REGULATOR</u>		M/N : <u>SDC-1000VA</u>	
Power Supply: <u>AC 230V, 50Hz</u>		criterion: B	
Ambient Condition : <u>24°C</u>		<u>55% RH</u>	
Operation Mode: On		Test Data: Apr. 03, 2013	
Inject Line : AC Mains	Inject Method: Direct	Inject Time(s): 120	
Line	Test Voltage	Result(+)	Result(-)
L	1.0kV	PASS	PASS
N	1.0kV	PASS	PASS
PE	1.0kV	PASS	PASS
L-N	1.0kV	PASS	PASS
L-PE	1.0kV	PASS	PASS
N-PE	1.0kV	PASS	PASS
L-N-PE	1.0kV	PASS	PASS
Signal Line			
DC Line			
Note :			
Remark:			

9. SURGE IMMUNITY TEST

9.1. Block Diagram of Test Setup

9.1.1. Block diagram of connection between the EUT and simulators



(EUT: AC. AUTOMATIC VOLTAGE REGULATOR)

9.1.2. Surge Test Setup

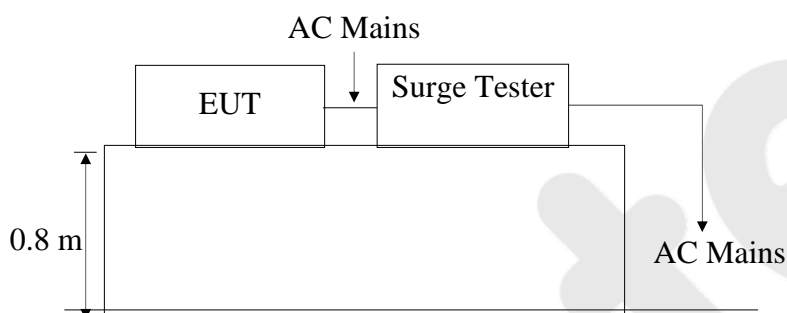

(EUT: AC. AUTOMATIC VOLTAGE REGULATOR)

9.2. Measuring Standard

EN 55024: 2010

IEC 61000-4-5: 2005

Severity Level: Level 2, Line to Line: 1.0kV; Level 3: Line to Earth :2.0kV

9.3. Severity Levels and Performance Criterion

9.3.1. Severity level

Severity Level	Open-Circuit Test Voltage kV
1	0.5
2	1.0
3	2.0
4	4.0
*	Special

9.3.2. Performance criterion: **B**

9.4. EUT Configuration

The configuration of EUT are listed in Section 2.4.1.

9.5. Operating Condition of EUT

Same as conducted emission measurement, which is listed in Section 2.5, except the test set up replaced by Section 9.1.1.

9.6. Test Procedure

- 1) Set up the EUT and test generator as shown on Section 9.1.2.
- 2) For line to line coupling mode, provide a 1.0 kV 1.2/50us voltage surge (at open-circuit condition) and 8/20us current surge to EUT selected points.
- 3) For line to earth coupling mode, provide a 2.0 kV 1.2/50us voltage surge (at open-circuit condition) and 8/20us current surge to EUT selected points.
- 4) At least 5 positive and 5 negative (polarity) tests with a maximum 1/min repetition rate are conducted during test.
- 5) Different phase angles are done individually.
- 6) Record the EUT operating situation during compliance test and decide the EUT immunity criterion for above each test.

9.7. Test Equipment

The following test equipments are used during the Surge Immunity measurement:

Item	Equipment	Manufacturer	Model No.	Serial No.	Last Cal.	Cal. Interval
1.	6kV Surge Generator	EMPEK	LSG-5060G	06010017N	Jul. 01, 2012	1 Year

9.8. Measuring Results

PASS.

Please refer to the following page.

Surge Immunity Test Results

Anbotek Compliance Laboratory Limited

Applicant : Zhongshan Dianxing Electrical Appliance Industry Co., Ltd. EUT : AC. AUTOMATIC VOLTAGE REGULATOR M/N : SDC-1000VA Power Supply: AC 230V, 50Hz Test Engineer: Jimmy Zhou				Test Date: Apr. 03, 2013 Temperature: 24°C Humidity: 55% Test Mode: On Criterion: B	
Location	Polarity	Phase Angle	Number of Pulse	Pulse Voltage (kV)	Result
L-N	+	0°	5	1.0	PASS
	+	90°	5	1.0	PASS
	+	180°	5	1.0	PASS
	+	270°	5	1.0	PASS
	-	0°	5	1.0	PASS
	-	90°	5	1.0	PASS
	-	180°	5	1.0	PASS
	-	270°	5	1.0	PASS
L-PE	+	0°	5	2.0	PASS
	+	90°	5	2.0	PASS
	+	180°	5	2.0	PASS
	+	270°	5	2.0	PASS
	-	0°	5	2.0	PASS
	-	90°	5	2.0	PASS
	-	180°	5	2.0	PASS
	-	270°	5	2.0	PASS
N-PE	+	0°	5	2.0	PASS
	+	90°	5	2.0	PASS
	+	180°	5	2.0	PASS
	+	270°	5	2.0	PASS
	-	0°	5	2.0	PASS
	-	90°	5	2.0	PASS
	-	180°	5	2.0	PASS
	-	270°	5	2.0	PASS
Remark:					

10. INJECTED CURRENTS SUSCEPTIBILITY TEST

10.1. Block Diagram of Test Setup

10.1.1. Block diagram of connection between the EUT and simulators



10.1.2. Block Diagram of Test Setup

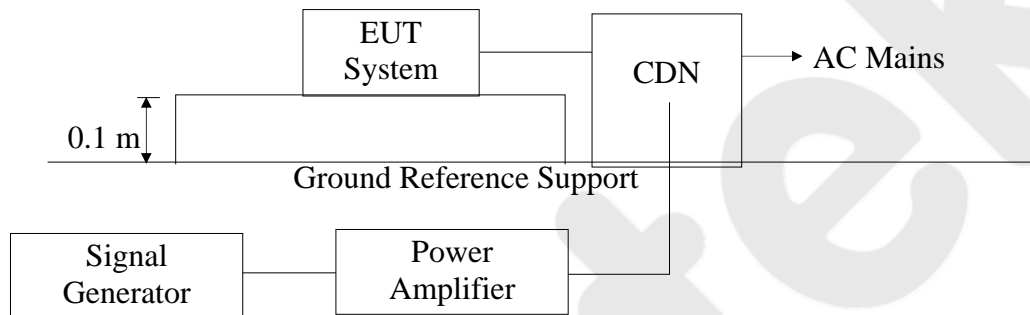

(EUT: AC. AUTOMATIC VOLTAGE REGULATOR)

10.2. Measuring Standard

EN 55024: 2010

IEC 61000-4-6: 2008, Severity Level 2: 3V (rms), (0.15MHz ~ 80MHz)

10.3. Severity Levels and Performance Criterion

10.3.1. Severity level

Level	Field Strength V(rms)
1.	1
2.	3
3.	10
X	Special

10.3.2. Performance criterion: A

10.4. EUT Configuration

The configuration of EUT are listed in Section 2.4.1.

10.5. Operating Condition of EUT

Same as conducted emission measurement, which is listed in Section 2.5, except the test set up replaced by Section 10.1.

10.6. Test Procedure

10.6.1. For AC Mains

- 1) Set up the EUT, CDN and test generators as shown on Section 10.1.2.
- 2) Let the EUT work in test mode and measure it.
- 3) The EUT are placed on an insulating support 0.1m high above a ground reference plane. CDN (coupling and decoupling device) is placed on the ground plane about 0.3m from EUT. Cables between CDN and EUT are as short as possible, and their height above the ground reference plane shall be between 30 and 50 mm (where possible).
- 4) The disturbance signal described below is injected to EUT through CDN.
- 5) The EUT operates within its operational mode(s) under intended climatic conditions after Power on.
- 6) The frequency range is swept from 150KHz to 80MHz using 3V signal level, and with the disturbance signal 80% amplitude modulated with a 1KHz sine wave.
- 7) The rate of sweep shall not exceed 1.5×10^{-3} decades/s. Where the frequency is swept incrementally, the step size shall not exceed 1% of the start and thereafter 1% of the preceding frequency value.
- 8) Recording the EUT operating situation during compliance testing and decide the EUT immunity criterion.

10.6.2. For signal lines and control lines ports:

No I/O ports. It's unnecessary to test.

10.6.3. For DC output line ports:

It's unnecessary to test.

10.7. Test Equipment

The following test equipments are used during the Injected Current Susceptibility measurement:

Item	Equipment	Manufacturer	Model No.	Serial No.	Last Cal.	Cal. Interval
1.	Conducted Immunity System	FRANKONIA	CIT-10	PI126530	May 19, 2012	1 Year
2.	CDN	FRANKONIA	CDN L-801 M2 / M3	TI126545	May 19, 2012	1 Year
3.	Electromagnetic Injection Clamp:	FRANKONIA	EM101	ST126115	May 19, 2012	1 Year
4.	Fixed Coaxial Attenuators	FRANKONIA	59-6-33	AB1261DD	May 19, 2012	1 Year

10.8. Measuring Results

PASS.

Please refer to the following page.

Injected Currents Susceptibility Test Results

Anbotek Compliance Laboratory Limited

Applicant: Zhongshan Dianxing Electrical Appliance Industry Co., Ltd. EUT : AC. AUTOMATIC VOLTAGE REGULATOR M/N : SDC-1000VA Power Supply : AC 230V, 50Hz		Test Date : Apr. 03, 2013 Temperature : 24°C Humidity : 53% Test Engineer : Jimmy Zhou		
Test Mode : On				
Frequency Range (MHz)	Injected Position	Strength (Unmodulated)	Criterion	Result
0.15 ~ 80	AC Mains	3V	A	PASS
Test Mode :				
Frequency Range (MHz)	Injected Position	Strength (Unmodulated)	Criterion	Result
Remark :			Note:	

11. VOLTAGE DIPS AND INTERRUPTIONS TEST

11.1. Block Diagram of Test Setup

11.1.1. Block diagram of connection between the EUT and simulators

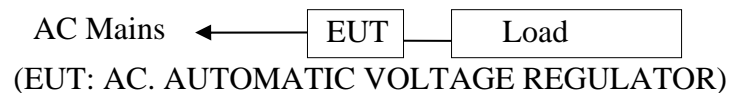

11.1.2. Dips Test Setup

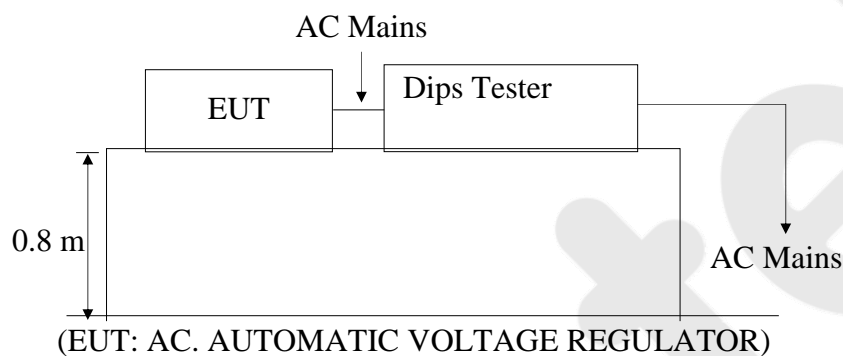

11.2. Measuring Standard

EN 55024: 2010
IEC 61000-4-11: 2004

11.3. Severity Levels and Performance Criterion

11.3.1. Severity level

Test Level %U _T	Voltage dip and short interruptions %U _T	Duration (in period)
0	100	0.5
40	60	1
		5
70	30	10
		25
0	100	50
		*

11.3.2. Performance criterion: **B&C**

11.4. EUT Configuration

The configuration of EUT are listed in Section 2.4.1.

11.5. Operating Condition of EUT

Same as conducted emission measurement, which is listed in Section 2.5, except the test set up replaced by Section 11.1.

11.6. Test Procedure

- 1) Set up the EUT and test generator as shown on Section 11.1.2.
- 2) The interruptions is introduced at selected phase angles with specified duration.
- 3) Record any degradation of performance.

11.7. Test Equipment

The following test equipments are used during the Dips Immunity measurement:

Item	Equipment	Manufacturer	Model No.	Serial No.	Last Cal.	Cal. Interval
1.	CYCLE SAG Simulator	PRIMA	DRP61011A	PR10106201	May 19, 2012	1 Year

11.8. Measuring Results

PASS.

Please refer to the following page.

Voltage Dips and Interruptions Test Results

Anbotek Compliance Laboratory Limited

Applicant : Zhongshan Dianxing Electrical Appliance Industry Co., Ltd. EUT : AC. AUTOMATIC VOLTAGE REGULATOR M/N : SDC-1000VA Power Supply : AC 230V, 50Hz	Test Date : Apr. 03, 2013 Temperature : 24°C Humidity : 55% Test Engineer : Jimmy Zhou
---	---

Test Mode: On

Test Level % U _T	Voltage Dips & Short Interruptions % U _T	Duration (in periods)	Criterion <input type="checkbox"/> A <input checked="" type="checkbox"/> B <input checked="" type="checkbox"/> C <input type="checkbox"/> D	Result P=PASS F=Fail
0	100	0.5P	B	PASS
40	60	5P	B	PASS
70	30	25P	C	PASS
0	100	250P	C	PASS

Test Mode :

Test Level % U _T	Voltage Dips & Short Interruptions % U _T	Duration (in periods)	Criterion <input type="checkbox"/> A <input type="checkbox"/> B <input type="checkbox"/> C <input type="checkbox"/> D	Result P=PASS F=Fail

Remark:

12. PHOTOGRAPHS

12.1. Photo of Power Line Conducted Emission Test



12.2. Photo of Radiated Emission Test

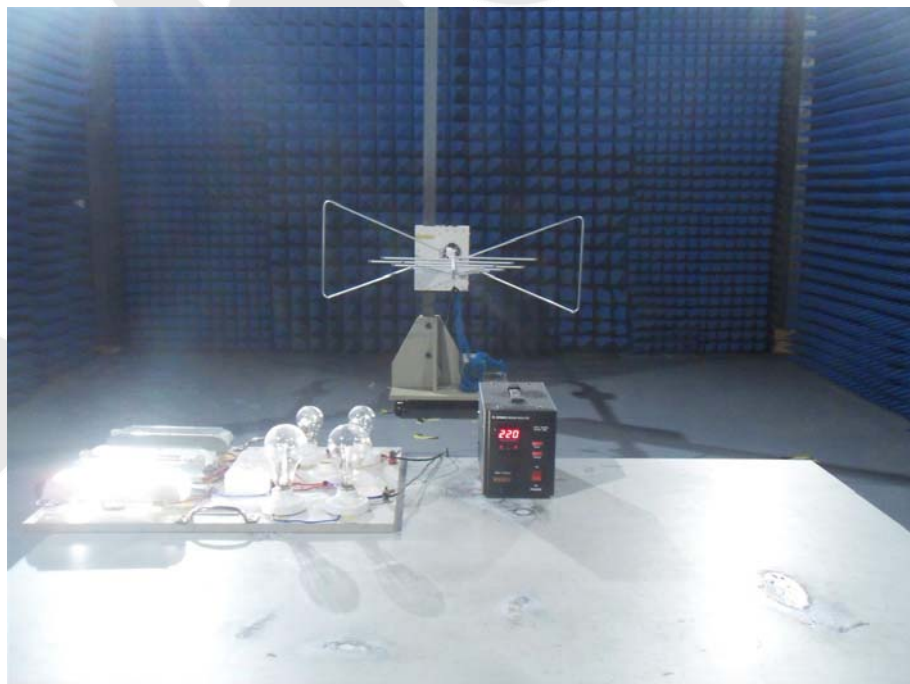

12.3. Photo of Flicker/Harmonic Test

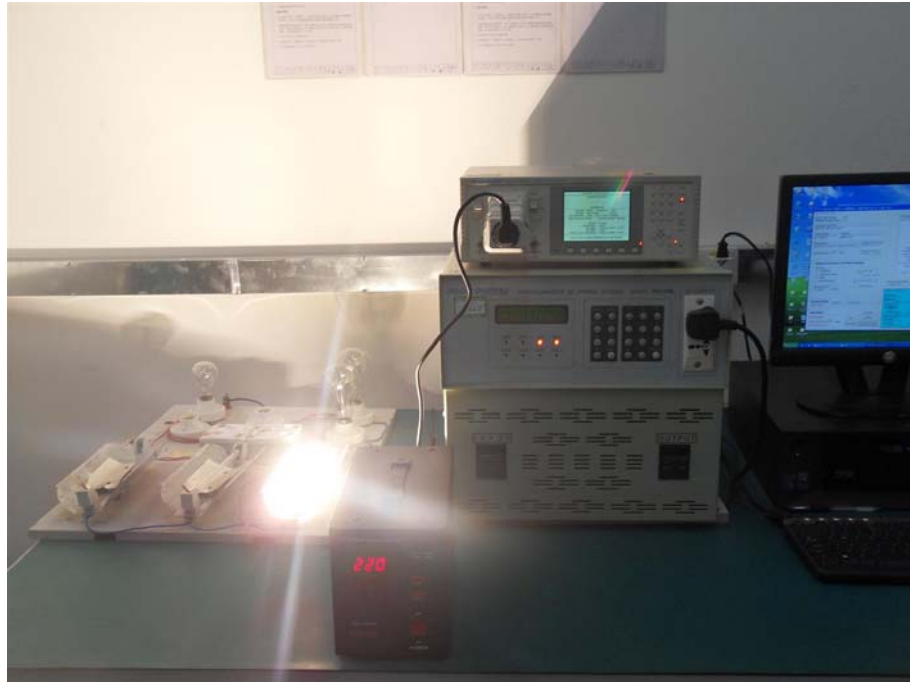

12.4. Photo of RF Field Strength susceptibility Test

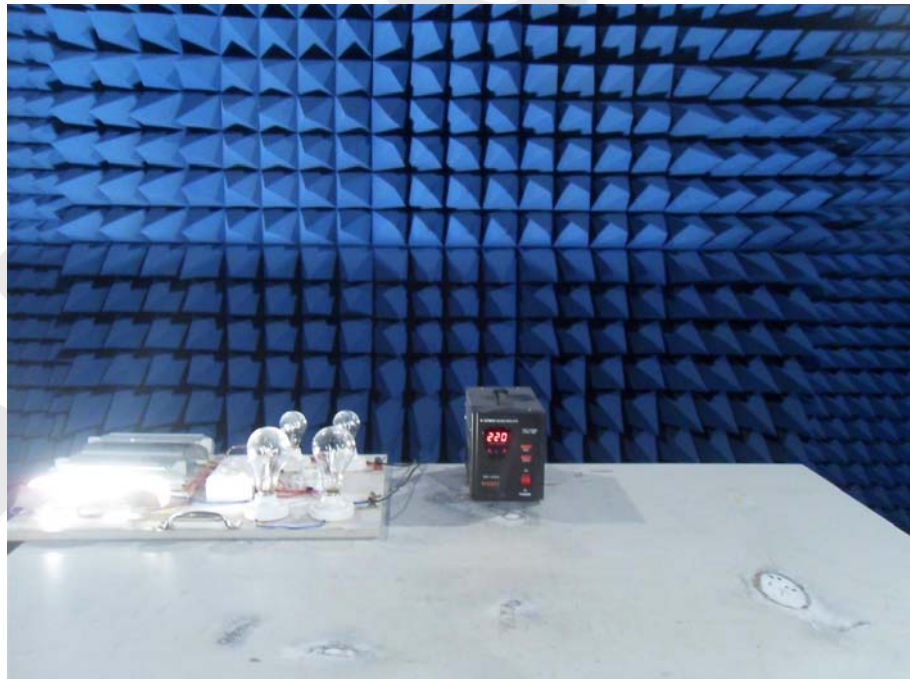

12.5. Photo of Electrical Fast Transient/Burst Immunity Test



12.6. Photo of Surge Immunity Test



12.7. Photo of Voltage Dips and Interruptions Test



12.8. Photo of Injected Currents Susceptibility Test

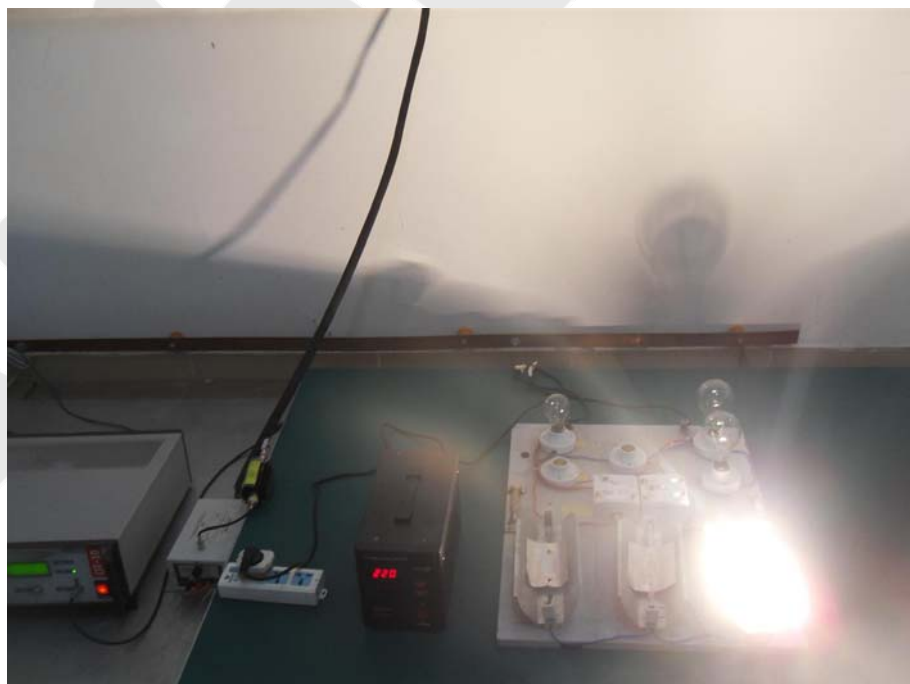

12.9. Photo of Electrostatic Discharge Test

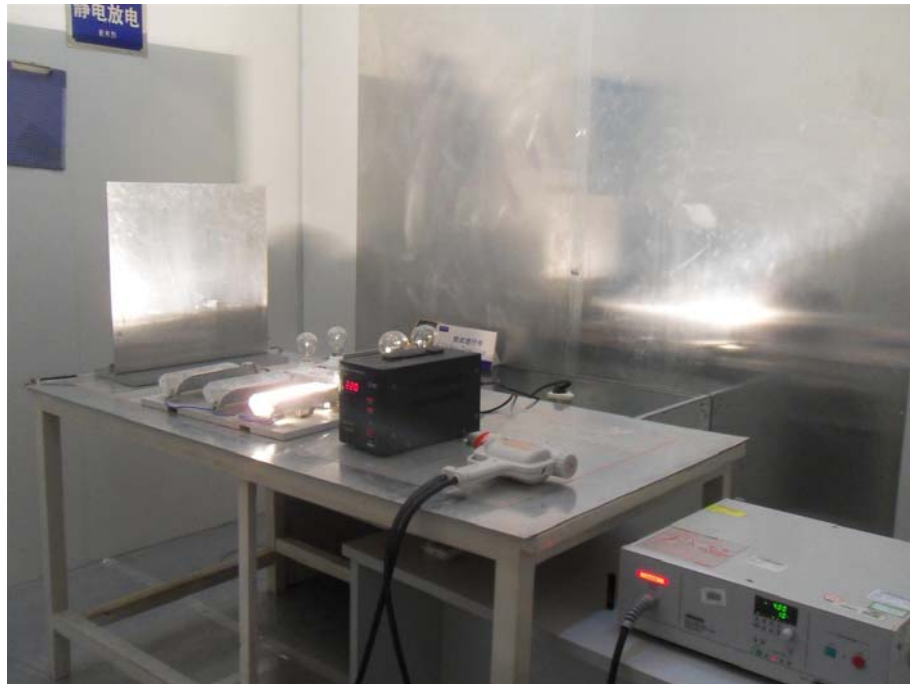

APPENDIX I
(Photos of EUT)

Anbotek

Figure 1
The EUT-Front View



Figure 2
The EUT-Back View



Figure 3
The EUT-Inside View

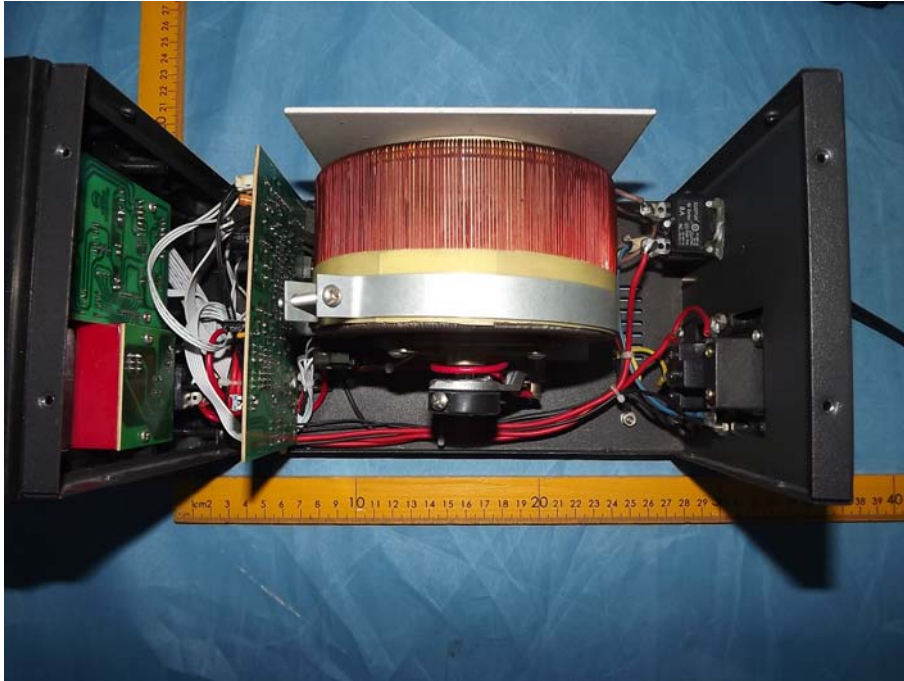

Figure 4
PCB of the EUT-Front View

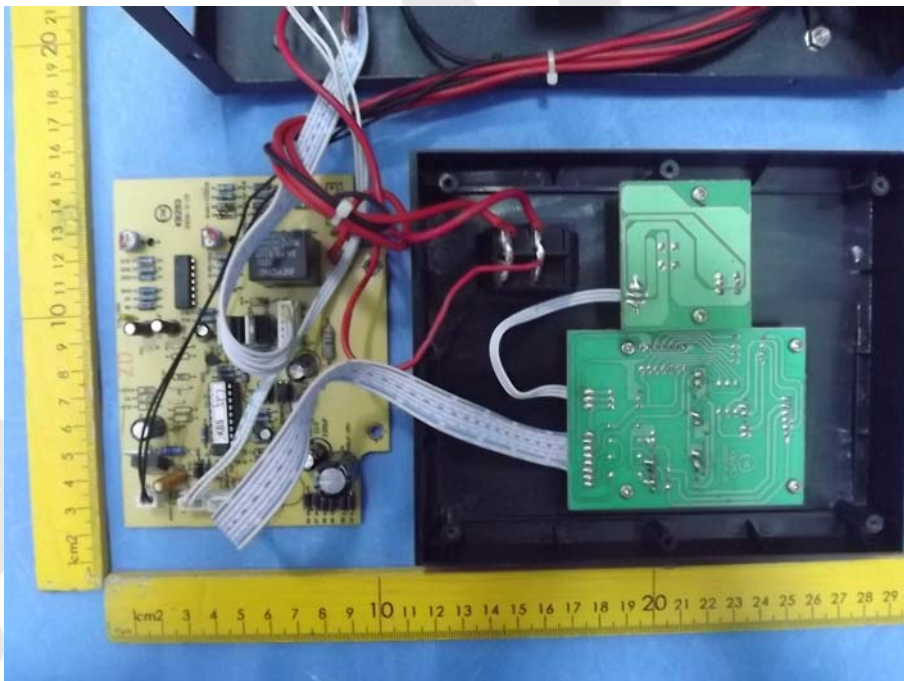
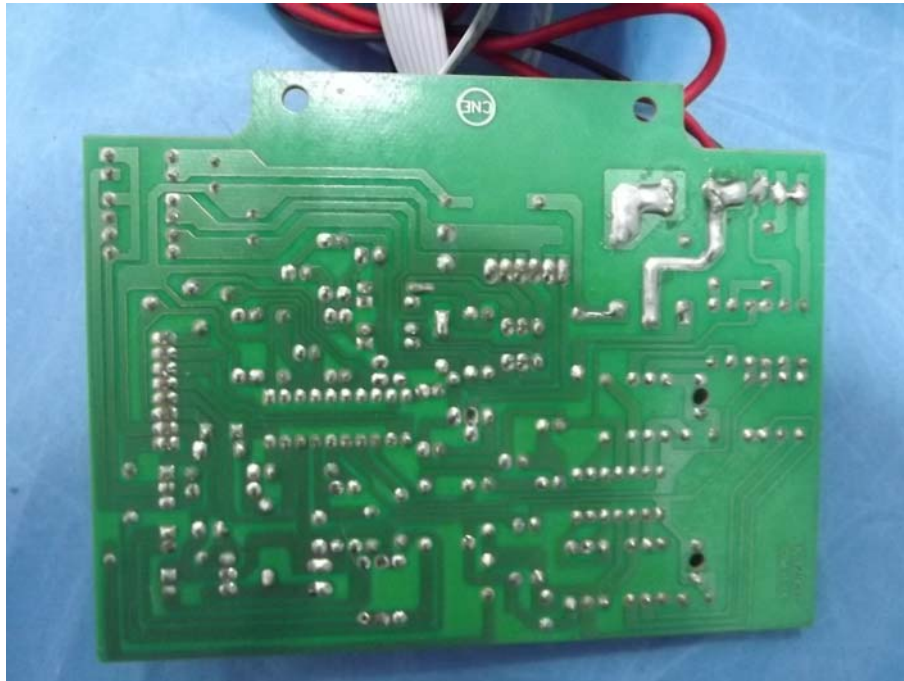

Figure 5
PCB of the EUT-Back View



Anbotek

APPENDIX II
(CE Label)

Anbotek

CE Label

1. The CE conformity marking must consist of the initials 'CE' taking the following form:
If the CE marking is reduced or enlarged, the proportions given in the above graduated drawing must be respected.
2. The CE marking must have a height of at least 5 mm except where this is not possible on account of the nature of the apparatus.
3. The CE marking must be affixed to the product or to its data plate. Additionally it must be affixed to the packaging, if any, and to the accompanying documents.
4. The CE marking must be affixed visibly, legibly and indelibly.
It must have the same height as the initials 'CE'

Proposed Label Location on EUT

EUT Back View/proposed CE Mark Location

