

Table of Contents

Introduction	2
<i>Important Safety Information (Be Sure to Read)</i>	3
1. Overview	5
1.1 A2 Series	5
1.2 Front Panel	6
2. Installation	7
2.1 Placement	7
2.2 Back Panel	8
2.3 Connection.....	9
2.4 Recommended Cable Cross-section and Circuit Breakers (CBs)	10
2.5 Battery Placement and Connections.....	11
2.6 Communication with PC.....	15
2.7 User Outputs.....	15
3. Operation	16
3.1 Switching On.....	16
3.2 Switching Off.....	17
3.3 Operation Modes	18
3.4 User Menu	19
3.5 Automatic Battery Test.....	20
3.6 Overload	20
3.7 Audio Warnings.....	21
3.8 Warnings Table	21
4. Troubleshooting	23
5. Maintenance	24
6. Technical Specifications	25

Introduction

Thank you for choosing our **Uninterruptible Power Supply** product for protection of your electrical devices.

The A2 Series Uninterruptible Power Supply (UPS) was manufactured using the latest technology. We recommend you to read this manual to learn many specifications and superior features of your new UPS.

We do pay attention to the environmental impacts of this product. Example of some of our measures to protect environment are as follows:

- ✓ *Product design is based on economical size and high efficiency approach.*
- ✓ *Quality and uninterruptible power is provided without distorting source voltage.*
- ✓ *Manufacturing is carried out in our ISO 14001:2004 Environment Management System certified factory.*
- ✓ *It is ensured that battery and metal wastes are disposed properly.*

To discover the entire range of our products and to receive up-to-date information, please visit our web site:

.....

Before you call us...

If you require assistance for a failure or any related issues, call our **Technical Support Center**.

For quick assistance, please have the following information available.

Model	A2 Series
Power (KVA)
Serial Number
Purchase Date
Installation Date
Mains Voltage/Frequency
Battery Quantity x Ah
Company

The A2 Series products are protected under a patent. Therefore, implementation of our proprietary technology by competitors is not permitted. Given the relevant standards and technology, device hardware configuration may be changed without notice. Technical specifications and dimension information are not binding unless formally confirmed by us.

IMPORTANT SAFETY INFORMATION (BE SURE TO READ)

Life Safety



- ! Use UPS in an access-restricted room (EN 62040-1-2).*
- ! The UPS has its own power source (batteries). Therefore, there may be live power at the output even if the mains voltage is disconnected.*
- ! There is dangerous level of voltage in the UPS, and it must be opened by an authorized service personnel only.*
- ! The UPS must be grounded in adherence to the rules.*
- ! Do not expose batteries to extreme high temperatures to prevent fire risks.*
- ! Do not attempt to open the battery. Chemical composition of the battery may be dangerous for your skin and eyes.*
- ! Adhere to all regulations that govern disposal of waste batteries.*

Safe Handling



- ! Be careful while carrying loads. Do not carry heavy loads without help.*
- ! Slide roller devices on smooth and even surfaces.*
- ! Do not use slopes with angles over 10°.*
- ! Adhere to following recommendations about load weights.*
 - ! An adult can carry loads up to 18 kg weight.*
 - ! Two adults can carry loads up to 32 kg weight.*
 - ! Three adults can carry loads up to 55 kg weight.*
 - ! Use pallet jack, forklift or similar devices for carrying loads over 55 kg weight.*
- ! Keep packaging material for use in case the UPS has to be transported to an authorized service or to another location.*

UPS Safety



- ! The UPS must be safeguarded against voltage overload or short circuit voltages by means of a readily accessible circuit breaker.*
- ! Do not operate the UPS at environment temperatures or relative humidity that exceeds the limits given in the manual.*
- ! Never operate the UPS in liquid environments or in overly humid environments.*
- ! Never allow water or foreign substances to penetrate in the UPS.*
- ! Strictly do not clog ventilation grids of the UPS.*
- ! Never expose the UPS to direct sunlight or a direct heat source.*
- ! The UPS' useful life is 10 years.*

Special Safety Information

- ! UPS' electrical connections must be provided as shown in the manual.
- ! Be sure to check the compatibility of the UPS power to mains voltage and to total load that will be supplied with UPS.
- ! UPS must be stored in a dry environment between -10°C and 45°C temperature prior to commissioning.
- ! UPS must be operated at least once a month continuously for 24 hours to charge the batteries.
- ! Because the battery life commences on the manufacture date, storage life is limited.
- ! UPS is designed to operate at height, operating environment temperature, relative humidity rate, and handling and storage conditions described in UPS manual.
- ! Special design and protection measures are essential for non-normal operating conditions. Such non-normal operating conditions include:
 - Harmful fume, dust, abrasive dust;
 - Humidity, vapor, bad weather, frost;
 - Explosive dust and gas mixtures;
 - Extreme temperature changes;
 - Poor ventilation;
 - Exposure to direct or radiated temperature from other sources;
 - Intensive electromagnetic fields and harmful radioactive levels;
 - Insects, pests, fungus, etc.



Change and Recycling of Batteries

- ! Battery poses electric shock hazard and short circuit risks.
- ! Replace only with batteries of same type, capacity, number and dimensions.
- ! Battery replacement must be carried out by trained service personnel only.
- ! Remove metal accessories such as wristwatch, ring, etc. and wear rubber shoes and gloves to prevent accidents and personal injury.
- ! Use tools with isolated handles.
- ! Make sure that battery connections are not grounded by mistake.
- ! Do not leave tools or metal pieces on batteries.
- ! **Batteries must be recycled.** Return mutilated batteries to any recycling facility or to company where you initially purchased them along with packaging material of new batteries.



UPS must be installed in strict adherence to following standards:

- ✓ HD 384.4.42 S1: Electrical Installation in Buildings, Chapter 4: Safety Protection Group 42: Protection Against Thermal Effects
- ✓ HD 384.4.482.S1: Electrical Installation in Buildings, Chapter 4: Safety Protection Group 48: Choosing Protective Measures Against External Effects – Section 482: Fire Protection in Places Bearing Special Risks or Dangers

1. Overview

1.1. A2 Series

UPS Cabin

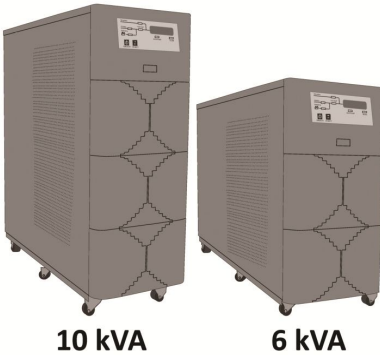

Dimensions	
UPS Power (KW/KVA)	Width x Height x Depth (mm)
4.2/6	255 x 545 x 640
7/10	255 x 710 x 660

Backup Time (min) (100% load/50% load)	Net Weight (kg)	
	6KVA	10KVA
0/0	30	35
2/4		65
3/9	60	77
4/11		85
5/13		98
6/16	72	
8/22	80	110

Figure 1.1 UPS Cabin

Table 1.1 UPS Cabin Dimensions and Weights

External Battery Cabin (optional)



Dimensions	
Width x Height x Depth (mm)	
255 x 710 x 640	

Backup Time (min) (100% load/50% load)	Net Weight (kg) (UPS Cabin/External Battery Cabin)	
	6KVA	10KVA
0/0	30/30	35/30
13/39		35/156
16/45	30/114	
22/63		35/180
26/73	30/130	98/156
30/82	30/156	
41/110		110/180
46/118	30/180	
69/173	80/180	

Figure 1.2 External Battery Cabin Dimensions and Weights

Table 1.2 External Battery Cabin

1.2. Front Panel

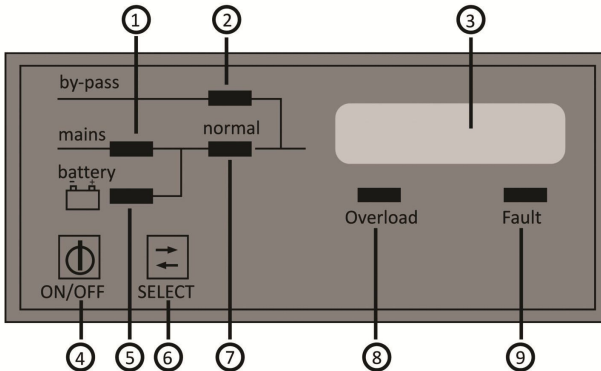

Figure 1.3 Front Panel

No.	LED	On	Off
1	mains	Mains voltage is within the tolerance limits.	Mains voltage is NOT within the tolerance limits.
2	by-pass	UPS is operating in bypass mode.	UPS is not operating in bypass mode.
5	battery	UPS is operating on battery.	UPS is not operating on battery.
7	normal	UPS is operating in normal mode.	UPS is not operating in normal mode.
8	Overload	See: '3.6. Overload'.	UPS is loaded 0% to 100%.
9	Fault	See: '3.8. Warning Table'.	No malfunction or warning.
3	Display	Liquid Crystal Display (LCD) where operation information is shown.	

No.	BUTTON	>3 seconds (Press and hold longer than 3 seconds)	<3 seconds (Press less than 3 seconds)
4	ON/OFF	<ul style="list-style-type: none"> ✓ On ✓ Off 	<ul style="list-style-type: none"> ✓ In normal mode: cancel execution/task ✓ In bypass mode: confirm execution/task ✓ Entry/exit to warning list ✓ Turning on/off warning sound
6	SELECT	<ul style="list-style-type: none"> ✓ Reversing the menu order 	<ul style="list-style-type: none"> ✓ Browsing through menu options ✓ Cancel switching to bypass mode

Table 1.3 Front Panel Operation

2. Installation

2.1. Placement

UPS Placement

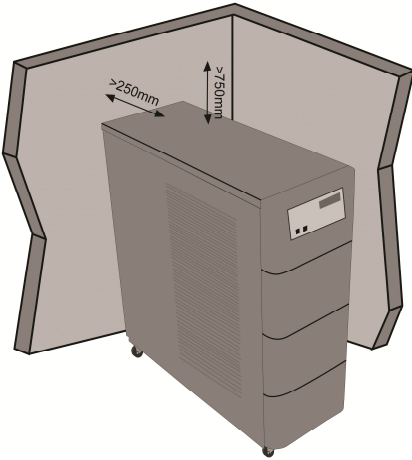

Figure 2.1 UPS Placement

- ! Do not install the UPS on an uneven ground or in outdoors.
- ! Note that ventilation holes on side covers must not be clogged.
- ! Do not install the UPS in places with liquid installation or places subject to fire risks.
- ! Do not install the UPS in places where it will be exposed to direct sunlight or affected of heat sources.
- ! Heed to minimum distance requirement between the UPS and nearby walls and/or devices.
- ! Do not install the UPS in places where it may be subject to vibration or impacts.
- ! Do not install the UPS in environments with excessive (too high or too low) humidity levels.
- ! Do not operate the UPS in dusty or filthy environments.



Do not leave any materials on or around the UPS to facilitate and expedite maintenance and repair operations.



The UPS may overheat if distance requirements are not met. Moreover, this may complicate maintenance and repair operations.



The UPS must be installed in a room with restricted access (Authorized Personnel Only).

External Battery Cabin Placement



✓ *Heed to UPS placement instructions when placing the external battery cabin.*

Figure 2.2 External Battery Cabin Placement

2.2. Back Panel

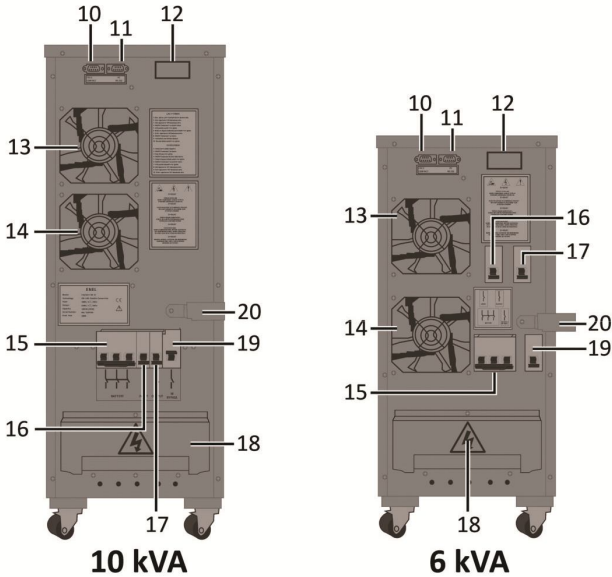
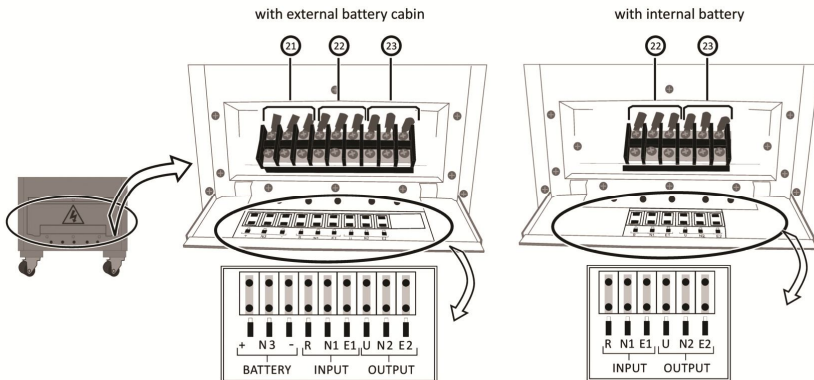

Figure 2.3 Back Panel

No.	Part	Function
10	User Outputs	This ensures that 'Low Battery' and 'Mains Failure' warnings can be monitored from a remote location by means of audible warning device or lamp.
11	RS232 Port	This ensures that the UPS can be monitored using a computer software.
12	SNMP Port	Metal cover is removed and adaptor is plugged in to this port if SNMP is used (<i>optional</i>).
13	Fan 1	This is the cooling fan for the inverter unit.
14	Fan 2	This is the cooling fan for the rectifier unit.
15	Internal Battery Circuit Breaker	This is used to switch on internal battery energy and to protect UPS.
16	Input Circuit Breaker	This is used to switch on/off mains voltage and to protect UPS.
17	Output Circuit Breaker	This is used to switch on/off load energy and to protect the load.
18	Terminal Cover	This is used to prevent the contact with live contacts.
19	Manual Bypass Circuit Breaker	This ensures that loads are supplied mains voltage during a malfunction or maintenance.
20	Manual Bypass Circuit Breaker Cover	This is used to prevent unauthorized persons' intervention to normal operation.

Table 2.1 Back Panel Operation

2.3. Connection



No.	Connections			
21	BATTERY <i>(External Battery Cabin)</i>	+	N3	-
		(+) pole	Middle point	(-) pole
22	INPUT	R	N1	E1
		Phase-R	Neutral	Earth
23	OUTPUT	U	N2	E2
		Phase-U	Neutral	Earth

Table 2.2 Terminals

2.4. Recommended Cable Cross-section and Circuit Breakers (CBs)

	Cable Cross-section (mm ²)		Circuit Breaker	
	6KVA	10KVA	6KVA	10KVA
Input	3x4	3x6	1x50	C 1x50A
Output	3x4	3x6	1x50	C 1x50A
Internal Battery			3x40	C 3x40A
External Battery	3x4	3x6	3x40	C 3x40A
Manual Bypass			1x50	C 1x50A

Table 2.3 Cable Cross-section and Circuit Breakers



The cables and the CBs must be replaced with the cables and the CBs of same type and capacities only. The CBs must be of time delay type.

2.5. Battery Placement and Connections

10KVA

- 30 pieces of 7-9Ah

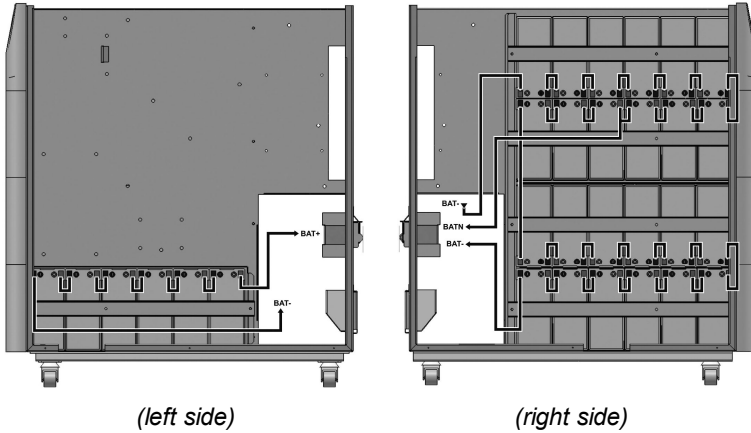

Figure 2.5 30 pieces of 7-9Ah Battery Placement and Connections

- 20 pieces of 7-9Ah

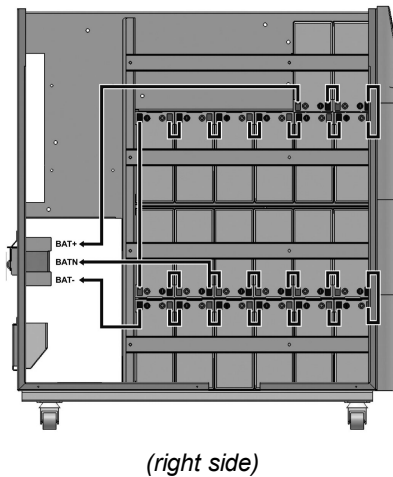
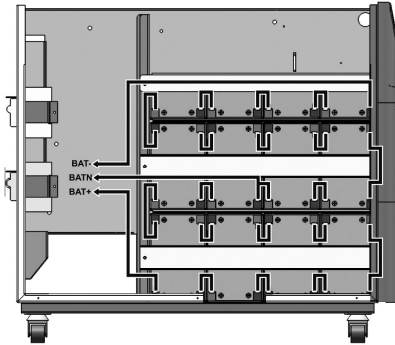

Figure 2.6 20 pieces of 7-9Ah Battery Placement and Connections

6KVA

- **20 pieces of 4.5Ah**



(right side)

Figure 2.7 20 pieces of 4.5Ah Battery Placement and Connections

- **20 pieces of 7-9Ah**

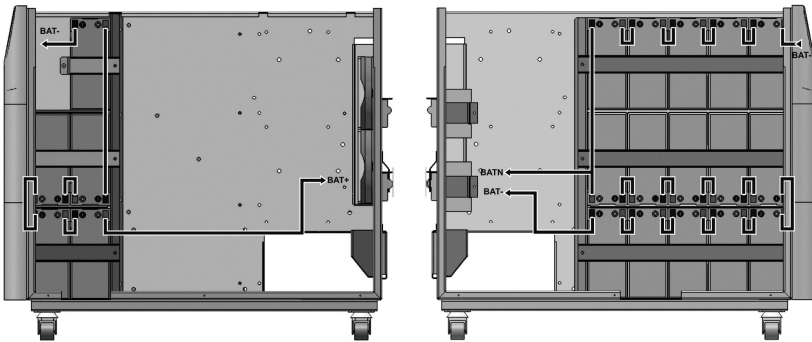

(left side)

(right side)

Figure 2.8 20 pieces of 7-9Ah Battery Placement and Connections

External Battery Cabin

- 30 pieces of 7-9Ah

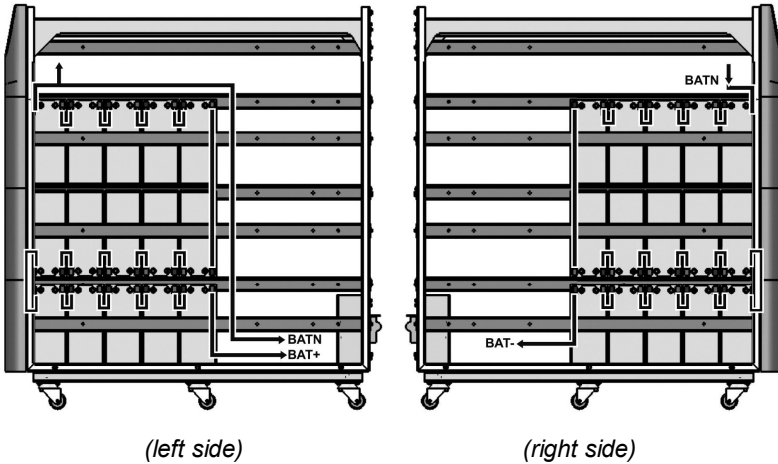

Figure 2.9 30 pieces of 7-9Ah Battery Placement and Connections

- 2x20 pieces of 7-9Ah

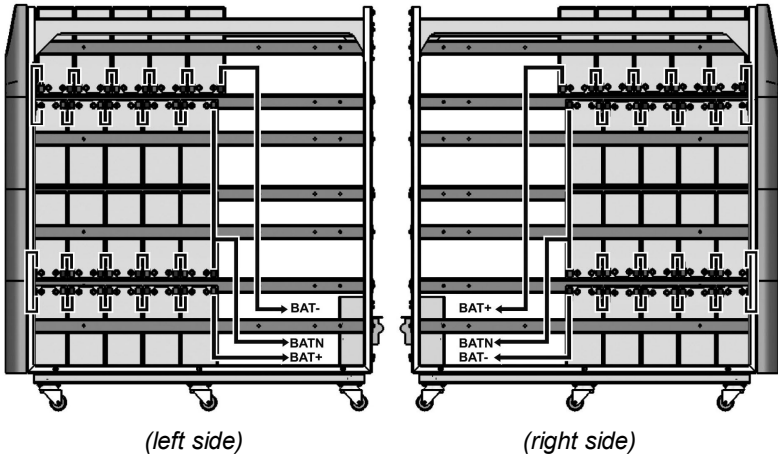

Figure 2.10 2x20 pieces of 7-9Ah Battery Placement and Connections

➤ **3x20 pieces of 7-9Ah**

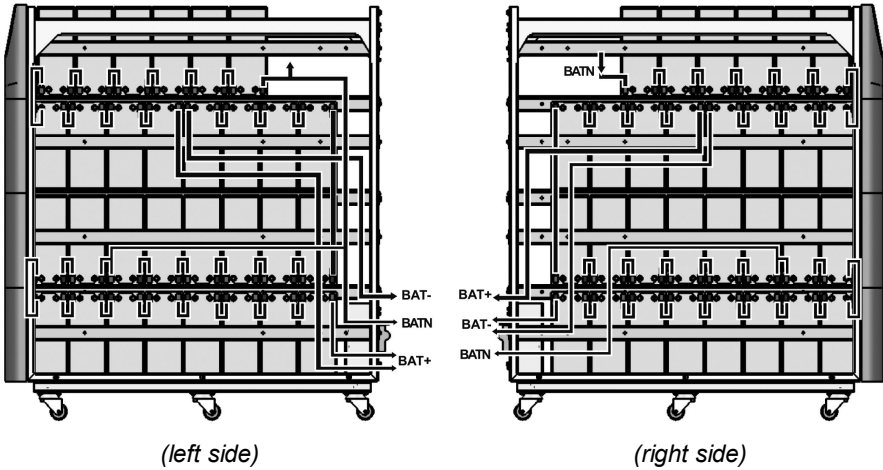

Figure 2.11 3x20 pieces of 7-9Ah Battery Placement and Connections

➤ **2x30 pieces of 7-9Ah**

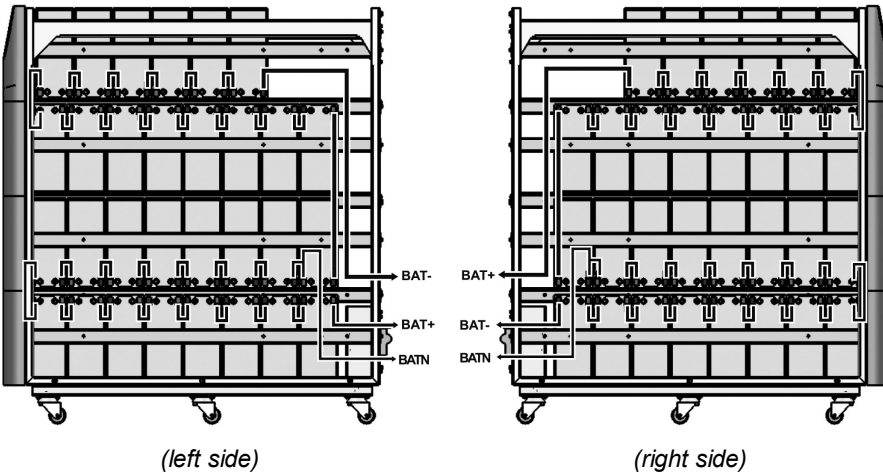

Figure 2.12 2x30 pieces of 7-9Ah Battery Placement and Connections

2.6. Communication with PC

RS232

You can monitor the UPS over RS232 port using *UPSilon2000* software that you will install on your computer (*this is optional and therefore UPS software and RS232 cable must be ordered prior to use of this option*). Using this software, you can monitor real-time UPS voltage and current information, battery information, malfunctioning warnings, etc. and save long term logs with graphics. In addition, software shuts down your computer and/or server safely in case of any electrical power outage.

SNMP

SNMP (*Simple Network Management Protocol*) is an advanced communication protocol. Using SNMP, multiple UPSs can be synchronously monitored and managed from a single common center. SNMP can be connected to a computer or a network over an 'Ethernet' communication port. An IP (Internet Protocol) number assigned to SNMP is used to connect to a UPS from anywhere on the network and monitor real time operation information, save long term logs, carry out testing, and turn on/off the UPS or the server.



Figure 2.13 SNMP Communication

2.7. User Outputs

When you use the UPS in environments where the UPS cannot be under consistent surveillance, you can have remote signals for power outage, audibly or visually. Using the outputs mentioned on a simple bell, siren or light circuit, the mains voltage and the battery capacity can be monitored. In this way, loads can be protected by being safely shut down.

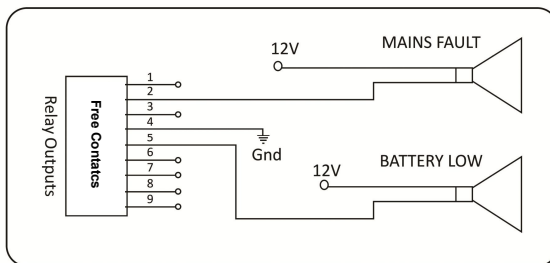

Figure 2.14 User Outputs

3. Operation

3.1. Switching On

1. Switch on the *Input CB* first and then the *Battery CB* (Figure 3.1). Press and hold the *ON/OFF* button until a warning beep sound, meanwhile observe the *normal* LED is on (Figure 3.2).

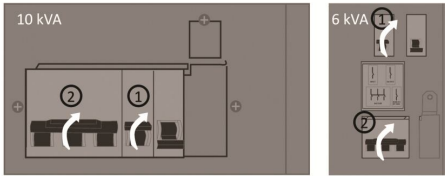

Figure 3.1

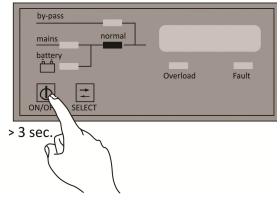

Figure 3.2

2. If the mains voltage and the frequency are within the limits, the *mains* and the *by-pass* LEDs will be on (Figure 3.3). If they are out of the limits, the *Fault* LED will be on and a warning beep will be heard (Figure 3.4).

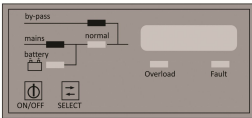

Figure 3.3

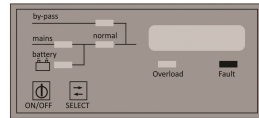

Figure 3.4

3. If the *mains* and the *by-pass* LEDs are on, press the *ON/OFF* button shortly and observe the '*Mains Start*' warning (Figure 3.5). If the *Fault* LED is on, press the *ON/OFF* button shortly to turn off the audible warning, press shortly again to see '*Battery Start*' warning (Figure 3.6) and wait until *normal* LED is on.

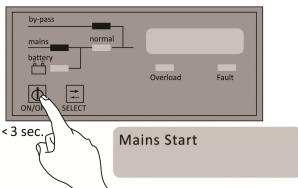

Figure 3.5

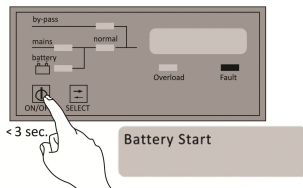

Figure 3.6

4. If the UPS started on mains voltage, LEDs will be on as shown in (a), otherwise they will be on as shown in (b) (Figure 3.7). In this case, you can switch on *Output CB* and supply your loads from the UPS (Figure 3.8).

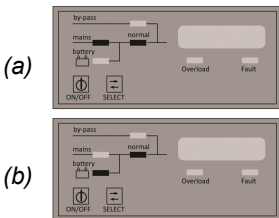

Figure 3.7

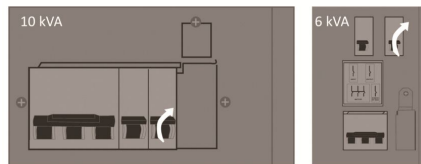

Figure 3.8

3.2. Switching Off

1. **If the UPS is in Normal Mode:** Switch off your loads safely. Press the *ON/OFF* button briefly. Press the *ON/OFF* button briefly again to confirm bypass operation and observe the *by-pass* and the *mains* LEDs turn on (*Figure 3.9, Figure 3.10*).

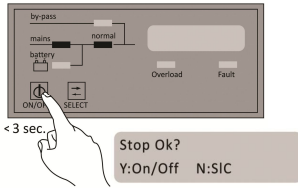

Figure 3.9

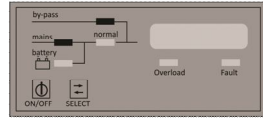

Figure 3.10



The UPS must be operated in bypass mode prior to fully switching off after normal mode.

2. **If the UPS is in Bypass Mode:** Press and hold the *ON/OFF* button until the warning beep silences (*Figure 3.11*). Observe that the display is fully switched off. Switch off the output, the battery, and the input CBs in respective order (*Figure 3.12*).

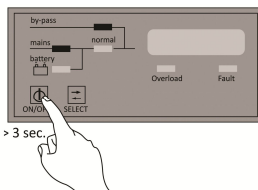

Figure 3.11

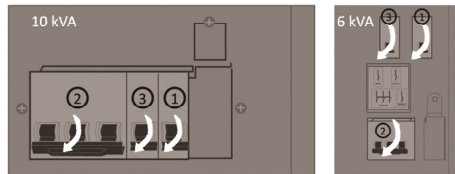

Figure 3.12

3. **If the UPS is in Battery Mode:** Press and hold the *ON/OFF* button until warning beep silences (*Figure 3.13*). Observe that the display is fully switched off. Switch off the output, battery, and input CBs in respective order (*Figure 3.12*).

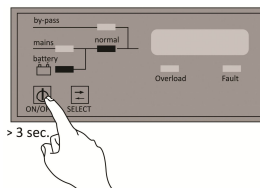

Figure 3.13

3.3 Operation Modes

The A2 Series UPS has *Online Double Conversion UPS* and *Three-Level Inverter* technologies. Three-Level Inverter Technology ensures that UPS operates at high efficiency. The A2 Series UPS supports following operation modes.

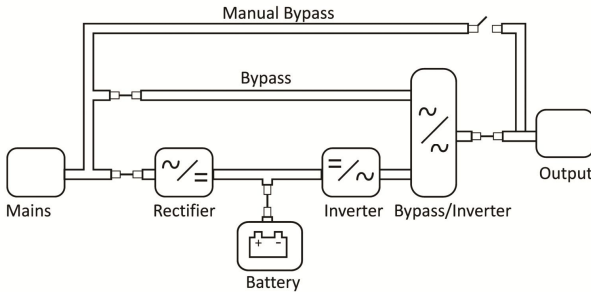

Figure 3.14

Bypass Mode

Mains voltage is transferred to output via bypass line and over bypass/inverter unit. Bypass operation is used for supplying the UPS from the mains voltage in case of any malfunctions. In case of malfunction or warning, bypass line will be used and malfunction will not affect the load. Meanwhile batteries are not charged or battery capacity will not diminish (*discharge*). Once mains voltage is interrupted, output voltage will also interrupt.

Normal Mode

Rectifier and inverter units operate. A mains-independent, stable voltage and frequency is generated and transferred to output via bypass/inverter unit. Batteries are charged as appropriate.

Battery Mode

When mains voltage and frequency is out of tolerance limits, rectifier unit does not operate. Inverter unit operate on batteries and supply the output voltage from batteries. A stable voltage and frequency is generated and transferred to output via bypass/inverter unit.

Manual Bypass Mode

This is the operation mode that is used to separate the UPS from input energy and supply the loads from the mains voltage in case of a maintenance or malfunction (*please see '3.2 Switching Off' and Figure 3.15 for details*).



The input and the battery CBs must be switched off while the UPS operates in manual bypass mode.



If the UPS will be operated in manual bypass mode without switching off the loads, it must be operated in bypass mode at first. Later, manual bypass CB must be switched on, and the output, the battery and the input CBs must be switched off in respective order (Figure 3.15).

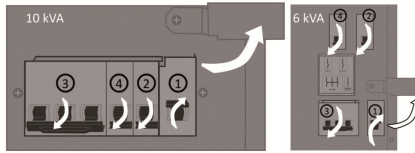

Figure 3.15



User will be responsible for any load malfunctions that may be experienced when switched to manual bypass mode without switching off the loads first.

3.4 User Menu

01-MAINS

Instant information for mains voltage is displayed.

01-MAINS
220V 50.0Hz

02-BYPASS

Instant information for bypass voltage is displayed.

02-BYPASS
220V 50.0Hz

03-OUTPUT

Instant information for output voltage and loading ratio is displayed.

03-OUTPUT
220V 50.0Hz 100%

04-INVERTER

Instant information for inverter voltage is displayed.

04-INVERTER
220V 50.0Hz

05-BATTERY

Instant information for battery charge voltage and capacity is displayed.

Note: The capacity percentage may NOT be exactly correct. Battery charge voltage is 270V for 6KVA, 270V or 405V for 10KVA.

05-BATTERY
270V 100%

05-BATTERY
405V 100%

06-DC-BUS

Instant information for DC bus voltages is displayed.

06-DC-BUS
+375V -375V

07-WARNING

The last 128 event log is recorded here.

07-WARNING

Normal Mode

000 00/00 00:00

Normal Mode

001 00/00 00:00

Mains Start



The date and the time of the events which are recorded in the log are not real-time.

08-PROGRAM NAME

Firmware name is displayed.

08-PROGRAM NAME

E111_04

3.5 Automatic Battery Test

The UPS self diagnoses the batteries by running on battery automatically at every 30 days. The testing process is run when the UPS is in normal mode. At the end of the test, the condition of the batteries (usable or not) is provided. When the *Automatic Battery Test* is negative, please contact with the Technical Service.



The 'Automatic Battery Test' may also be run after long power outages. In this case, the 'Battery Failure' test result should be disregarded.



An 'Automatic Battery Test' on batteries charged for at least 10 hours should be regarded.

3.6 Overload

During overload; the UPS may run in normal operating conditions for below defined-periods. The UPS goes to bypass mode when the below defined periods are exceeded.

Loading Ratio	Power (KVA)		Running Time
	6	10	
110% - 125%	6.6-7.5	11-12.5	60 seconds
125% - 150%	7.5-9	12.5-15	10 seconds
> 150%	>9	>15	3 seconds

Table 3.1 Overload Table



The UPS has 150% overload capacity at most when running in the bypass mode.

When the load ratio increases further, the UPS shuts down the output.

3.7 Audio Warnings

Subject	Alarm	Warning Info			
Battery	3 times consecutively at every 5 sec.	Battery High	Battery Low	UPS Shutdown	Battery Fault
	2 times consecutively at every 2 min.	Battery Test			
Load	3 times consecutively at every 5 sec.	Over Load			
Heat		Over Heat Inv		Over Heat Rec	
DC Bus		Dc High		Dc Low	
Mains		Mains High		Mains Low	
Bypass	2 times consecutively at every 2 min.	Bypass High		Bypass Low	
Failure	3 times consecutively at every 5 sec.	Inverter Fault		Over Current	
	2 times consecutively at every 2 min.	Frequency Fault			

Table 3.2 Audio Warnings

3.8 Warnings Table

The failure warnings constituting the UPS's event log and their operating info are as follows:

Event	Definition
Battery Fault ²	The batteries are expired (see. 3.5 Automatic Battery Test).
Battery High ²	The battery voltage is higher than required.
Battery Low ¹	The battery capacity is low.
Battery Mode ³	The UPS runs on battery.
Battery Start ³	The UPS is started when the mains voltage and/or the frequency are/is out of the defined ranges.
Battery Test ³	'Automatic Battery Test' is performed (see. 3.5 Automatic Battery Test).
Bypass High ¹⁻⁵	The mains voltage is higher than the upper limit. The UPS continues normal operation. But, if it passes to the bypass mode; no power at the output.
Bypass Low ¹⁻⁵	The mains voltage is less than the lower limit. The UPS continues normal operation. But, if it passes to the bypass mode; no power at the output.
Bypass Mode ²	The UPS transfers the mains voltage to the output.
Bypass Scr Fault ⁵	The UPS cannot transfer the mains voltage to the output.
Charger Failure ²	The batteries cannot be charged.
Dc High ²	The rectifier voltage above the upper limit.
Dc Low ²	The rectifier voltage below the lower limit.
Emergency Stop ⁵	The UPS output is shut down using the emergency stop switch.
Frequency Fault ³	The mains frequency is out of limits.
Inv Scr Fault ²	The inverter voltage cannot be transferred to the output.
Inverter Fault ²	The inverter unit cannot produce the required voltage.
Mains High ³	The mains voltage is above the upper limit.
Mains Low ³	The mains voltage is below the lower limit.

Mains Start⁴	The UPS is started when the mains voltage and the frequency are within the limits.
Normal Mode⁴	The UPS is in normal operation mode.
Output S/C⁵	Short circuit at the loads, at the output, at the beam box or at the line.
Over Curr Fault²	During the normal mode, instant high-current was drawn from the output at least 3 times consecutively.
Over Curr Igbt²	Internal malfunction in UPS or instant high current was drawn from the output during normal operation mode.
Over Current Byp⁵	Instant high current was drawn from the output during bypass mode.
Over Current Inv²	Instant high current was drawn from the output during normal mode.
Over Current Rec²	Instant high current was drawn from the input during normal mode.
Over Heat Inv²	The temperature of the cooler of the inverter unit is higher than 75°C.
Over Heat Rec²	The temperature of the cooler of the rectifier unit is higher than 75°C.
Over Load¹⁻²	The UPS is overloaded (<i>see. 3.6 Overload</i>).
Pwm Fault²	The inverter unit is faulty.
Stop Mode⁵	The UPS output shut down.
Synchron Fault²	The output voltage and the mains voltage is at different values.
UPS Shutdown⁵	The UPS has shut down the system, since the battery capacity is at its lowest.

Table 3.3 Warnings Table

1: UPS' operation mode remains unchanged.

2: UPS switches to bypass operation mode.

3: UPS switches to running on battery mode.

4: UPS switches to normal operation mode.

5: UPS shuts down the output.

4. Troubleshooting



Make sure you go through the table below before contacting the Technical Service.



Cable connections and CB checks must be performed by authorized personnel only.

Definition of Failure	Possible Cause	Solution
<i>UPS won't switch on and lights are OFF.</i>	<i>ON/OFF button is pressed to briefly.</i>	<i>Press and hold ON/OFF button for at least 3 seconds.</i>
	<i>CBs are switched off.</i>	<i>Switch on the CBs in appropriate order.</i>
	<i>Contact Technical Service.</i>	
<i>'Battery Mode' warning received.</i>	<i>Problem with cable connections.</i>	<i>Check input cable connections.</i>
	<i>CB failure.</i>	<i>Check the input CB.</i>
	<i>Mains voltage or frequency is out of limits.</i>	<i>Check the mains voltage and the frequency on the front panel.</i>
	<i>Contact Technical Service.</i>	
<i>Failure light is ON and UPS gives consistent audible warning.</i>	<i>The UPS may be giving 'Over Heat Rec' warning.</i>	<i>Check the UPS load ratio and the environment temperature. Shut down the UPS and wait for a while.</i>
	<i>The UPS may be giving 'Over Heat Inv' warning.</i>	<i>Check the UPS load ratio and the environment temperature. Shut down the UPS and wait for a while.</i>
	<i>The UPS may be giving 'Battery High' warning.</i>	<i>Contact Technical Service.</i>
	<i>The UPS may be giving 'Over Current' warning.</i>	<i>Turn the UPS off and on.</i>
	<i>The UPS may be giving 'Output S/C' warning.</i>	<i>Shut down the UPS. Make sure there is no short circuit on loads before switching the UPS back on.</i>
	<i>Contact Technical Service.</i>	
<i>Overload light is ON and UPS gives consistent audible warning.</i>	<i>'Over Load' warning.</i>	<i>Check the load ratio. Reduce the loads connected to the UPS output.</i>
<i>Time for running on battery is too low.</i>	<i>Batteries were not fully recharged.</i>	<i>Check back again once the batteries were recharged for at least 8 hours.</i>
	<i>Charger failure.</i>	<i>Contact Technical Service.</i>
	<i>Battery failure.</i>	<i>Contact Technical Service.</i>

Table 4.1 Troubleshooting Table

5. Maintenance



The UPS should only be opened by authorized personnel.



The UPS must be completely off during maintenance. Mains and battery connections must be disconnected and batteries must be moved away from the UPS.



Follow the 'Important Safety Information' and 'Installation' instructions during the maintenance.

- ! The electronic boards and the fans should be cleaned regularly.
- ! The ventilation holes on the lid should be cleaned regularly.
- ! The UPS body should be cleaned with a soft and moist cloth.
- ! The sturdiness of cable connections, screws and sockets should be checked.
- ! The board supply voltages should be measured and checked.
- ! The components on the boards and the other hardware should be checked.
- ! The voltages of the batteries should be checked by measuring the voltages separately.
- ! The accuracy of the calibration and the adjustments should be checked.
- ! The dust, the heat and the temperature in the UPS room should be checked.
- ! The instructions in the '*Important Safety Information and Installation*' should be complied.

6. Technical Specifications

TECHNICAL SPECIFICATIONS			
A2 SERIES			
Power (KVA)	6		10
INPUT			
Voltage	220 / 230 / 240 Vac 1ph + N		
Voltage tolerances	- 25%, +20% (without downgrading)		
Frequency	50 / 60 Hz		
Frequency tolerances	± 10%		
Power factor	≥ 0.99		
THDi	< 5%		
OUTPUT			
Voltage	220 / 230 / 240 Vac 1ph + N		
Voltage tolerances	± 1% (static load), dynamic load in accordance with VFI-SS-11		
Frequency	50 / 60 Hz		
Frequency tolerances	± 0.1% (self-synchronize), ± 1% (mains-synchronize)		
Power factor	0,7 (0,8 optional)		0,7
THDv	≤ 2% (linear load), ≤ 5% (non-linear load)		
Crest factor	3:1		
OVERLOAD CAPACITY			
≤ 110%	30 min.		
≤ 125%	60 sec.		
≤ 150%	10 sec.		
> 150%	3 sec.		
EFFICIENCY			
Online	up to 94%		
GENERAL			
Technology	Three level inverter, PFC		
Control	Microprocessor, SPWM		
Communication	SNMP, RS232		
Remote monitoring	SNMPView, UPSilon, Remote Monitoring Panel (Optional)		
Dry contacts	Battery mode, Battery low		
Custom inputs	Remote EPO		
Cold start	Standard		
Maintenance bypass	Standard		
ENVIRONMENT			
Operating temperature	from 0 °C up to +40 °C (from 20 °C to 25 °C for maximum battery life)		
Relative humidity	0% - 85% (without condensation)		
Maximum altitude	≤ 2000 m		
Noise level	< 40 dB (A)		< 45 dB (A)
UPS CABINET			
Dimensions (W x D x H) (mm)	255 x 640 x 545		255 x 660 x 710
Weight (kg)	29		35
Degree of protection	IP20		
Colour	RAL7012		
BATTERY CABINET			
Internal battery quantity	14	20	20 30
Internal battery capacity (Ah)	7-9		
External battery cabinet socket	standard		
STANDARDS			
Safety	EN 62040-1		
EMC	EN 62040-2		
UPS LIFETIME	10 years		

AUTHORIZED TECHNICAL SERVICE

